

US SCALEMASTERS

2008 Competition Guide

U.S. SCALEMASTERS



CHAMPIONSHIPS

- *Official Guide for Regional Qualifiers*
- *Grand Championships*
- *Judges Certification*
- *For Pilots, Builders, Contest Directors and Judges*

This Scale Masters Competition Guide is designed to include all aspects of Scale Aircraft Competition in one easy to read and understand document. Inside are important clarifications, clear explanations with diagrams of maneuvers, taking the mystery out of the judging aspect of Scale Competition. Also in this guide are steps to become a Certified Judge for the U.S. Scale Masters Association. This is the Official U.S. Scale Masters Competition Guide for all Regional Qualifiers and the U.S. Scale Masters Grand Championships. Enjoy our Sport!

Contact Person: Carolyn Van Herk (714) 839-3805
16285 Mt. Dana Circle
Fountain Valley, CA 92708
cvanherk@socal.rr.com

\$5.00

US SCALE MASTERS ASSOCIATION, INC.

U.S. SCALEMASTERS

Model Aircraft



CHAMPIONSHIPS 2008

U. S. Scale Masters Competition Guide Table of Contents

INTRODUCTION.....	ii
Our Mission	1
Purpose / Scope / Goal	1
What's New for this printing.....	1
Section I General Rules.....	6
Section II Safety	7
Section III Static Judging.....	9
Section IV Flight Judging	13
Section V Mandatory Maneuvers.....	16
Section VI Mechanical Options.....	21
Section VII Maneuver combinations.....	22
Section VIII Optional Flight Maneuvers	24
Section IX Miscellaneous Event Logistics	30
Section X JUDGES CERTIFICATION.....	35
Prerequisites.....	36
Certification Process.....	37
Static Judging Criteria.....	37
Flight Judging Instructions and Automatic Downgrades.....	39
Definitions.....	40
Builder of the Model Declaration	41
Official Protest Form.....	42
Pre-Flight Safety Inspection Checklist.....	43
Maneuver Declaration Sheet.....	44
Blank Score Sheets	46-49

U.S. Scale Masters



INTRODUCTION

You spend weeks, months and even years in the creation of your project, from ARF's to a never seen before scratch built masterpiece with all the bells and whistles.

You take your project to the field to fly for the first time and you are more nervous than ever before in your lifetime. As you taxi out, you can feel your heart beating, taste the adrenaline in your mouth, and try ever so hard not to let your transmitter antenna give away your shaking hands. As you roll forward on the throttle and concentrate on the rudder to keep you straight, the nerves seem to disappear. Now you are focused and there is no time for apprehension because you are busy. A little back pressure and you're flying. A turn downwind, time to make trim changes, and your creation has taken its place in the sky with those things that fly. There is a moment to catch your breath and to reflect on what you have done... A moment to inwardly smile and give yourself a much deserved "atta boy".

Back in the pits with your engine(s) shut down, there is a time to laugh with your friends. A time to say, "You see? I told you it would fly!" This is a time to share in the tight bond of comradie that you find in this realm; a realm of wonder where you are only bound by your ever growing ability and imagination.

Welcome guys and gals. Welcome to the exciting world of scale modeling. A world in which you recreate a full size aircraft in miniature and, whether you are a newcomer flying an ARF, or an expert standing at the pinnacle of success, there is a place and an event geared for you. Welcome to the friendly group of people just like you who are dedicated to scale flying and who yearly extend the genre beyond anything thought possible.

The following is the current 2008 USSMA Competition Guide through which we all function. This guide provides the "glue" which defines our direction and gives the association a common base from which we compete. The guide is in a constant state of flux in order to meet the changing technology and needs of our members, and is modified by the Board of Directors each year as needed. There is a great deal of information in this guide relative to all the events including maneuvers, judging, logistics, procedures, and so on. We highly recommend that you study the guide and become completely familiar with it all, but especially the requirements for the event in which you intend to compete. A clear understanding will greatly help to provide an exciting and fun-filled experience at the Qualifiers and Championship events.

So, once again, welcome aboard. We are always here to help...heavily stressing comradeship, education, sportsmanship, fun and a wide sense of humor. With your membership you have joined "the best of the best" who are dedicated to keeping our founder Harris Lee's dream alive. Thanks for your support and best wishes to all!

Bill

Bill Hart, National Chairman

Our Mission

The Scale Masters Association is committed to the development and growth of scale aircraft modeling by bringing people together to learn about the fascinating aspects of aviation, scale realism competition, and Sportsmanship.

Purpose / Scope / Goal

To provide a forum that can identify the best model and pilot combination of all through a series of local contests (regional qualifiers) and the annual Championship contest. The Grand Champion receives worldwide recognition and is automatically qualified to attend the next year's championships to defend his/her title. This Scale Masters Competition Guide is intended for use by contestants, static judges, flight judges, and contest directors at both Scale Masters Regional Qualifiers and the Scale Masters Championships. It outlines the ground rules, intent, and common definitions through which a contestant may present both his/her building and flying skills in a fair, competitive environment with an informed and effective base of knowledge.

It is not possible to write up a “rule” on each and every variation or possible condition that may come up during an event so using guiding principals that clarify intent is the primary purpose of this Guide. This allows a contestant to successfully compete with any kind of fixed wing aircraft they choose on an equal basis which does not limit or favor any type or era of aircraft (provided the aircraft actually flew in full size).

What’s New for this printing

One of the strengths of the Masters program is the ability to try new ideas that might improve judging scale models. In many cases these changes, once proven, eventually end up in other event rulebooks. This round of changes is based on what you, the customer, told us through surveys, e-mail, our Web Page, and through our Advisory Committee. The changes reflect our commitment to improving the quality of the program for the enjoyment of all.

- Advanced class added for top-level pilots, no BOM.
- Open class revised (no longer a Qualifying event).

The Contestants' Goal

To present the most accurate, well-constructed representation possible of the full size aircraft he/she has chosen to model according to the documentation package. It is the responsibility of the contestant to provide adequate documentation that proves his/her model represents a full size, man-carrying aircraft. The contestant, or designated pilot, should then fly this aircraft in the most realistic and prototypical fashion possible performing the documented maneuvers. Each aircraft type has its own problem set so it is up to the modeler to choose the maneuvers that are best suited for their aircraft. Only maneuvers that are prototypical of the full size aircraft should be chosen, and they should be performed as though observing the full-scale aircraft.

A high level of construction accuracy, excellent craftsmanship and superior flying skills will allow the successful contestants to collect the most points and win the competition.

The Judges' Goal

To provide a fair and accurate score based on the documentation the contestant has provided. Each judge will ask the primary question “Does it match?” at each decision point. The judges will refer to the contestant’s Static documentation package, Maneuver Declaration Sheets or published maneuver descriptions as the reference. In judging, a judge should not fall back on his/her remembrance of a specific full-scale aircraft’s detail or performance parameters in determining a contestant's score.

Instead the judge should rely on the contestant's documentation to communicate the scale details for static judging and capabilities or limitations of the full-scale aircraft for flight judging by how he/she intends to fly his/her model within a scale size realistic-performance envelope. The judges are only there to compare what the contestant says they are going to do in flight and what they actually do in flight.

General Requirements

1. All pilots must show proof of a current AMA Membership or Model Aeronautics Association of Canada.
2. Any scale model of a heavier than air, man carrying, fixed wing aircraft that was actually built and flown may be entered. If a pilot was visible in the full-scale aircraft, then a pilot figure of appropriate size **must** be in the model during the flight portions of competition.
3. Each Expert and Team contestant is required to sign a statement verifying he/she is the builder of the model entered (see Builder of the Model definition and Declaration in the back of this Guide).
4. All models will be subject to a general safety inspection before being allowed to fly. Any model involved in an incident resulting in structural damage may be required to undergo additional safety inspections before being allowed to continue the competition.

Qualifying for the U.S. Scale Masters Championship Event

The "Masters" is not an invitational event. The program is designed such that each contestant must earn their passage to the Championships by qualifying in one of the Regional Qualifiers. These Qualifiers will select the top 30% of total entries in Expert and Team, and 20% of the Advanced Class who have not already qualified. These top entries will be "qualified" to attend the U.S. Scale Masters Championship Event. This percent cutoff shall not be extended based on inability to attend. If there are contestants among the top percentage who have ALREADY qualified, they may be included in the overall attendance listing for determining the additional percentage who will qualify to go on to the Championships. If this calculation results in a mathematical fraction in qualified contestants, then the number qualified will be rounded up to the next whole number. For example, if seven contestants participated in Expert of which one had already been previously qualified, then 30% of seven contestants is 2.1. After rounding up to the next whole number from the 2.1 calculation, there will be 3 additional new people qualified beyond the one contestant already qualified.

The top 30% Expert and Team winners at the Championships are automatically qualified for the next Championships Event provided that the contestant is an entrant in at least one Qualifier during the following year regardless of placement position. Open class must qualify each year.

The winner in Expert class at each year's Championships event earns the rank and title of Grand Champion and is qualified for life provided they help out at their regional qualifier or support the Masters in some way each year. They can miss attending a Championship event or miss helping out at a qualifier for up to 3 years before they would have to re-qualify again.

USSMA Board of Directors may elect to allow up to 4 international competitors to attend the Championships, as there would be no official Regional Qualifiers to attend in their country. The selection is based on the modelers piloting capability, craftsmanship, and success in competing in local contests.

Entry Categories

- 1. Expert:** This category is for the builder-pilot and is the only category from which the Grand Champion is determined at the Championship Event. Those competing in Expert may also enter as either the builder or pilot in one Team class. Those competing in Expert may not compete in Advanced at the same contest. Regional qualifiers that include the AMA “Designer Scale”, “FAI/F4C”, or Top Gun “Master Class” may be combined with the Expert class at the Championships. The top 30% of “Designer”, “FAI/F4C” and “Master Class” entries at these events shall be qualified to attend the Championships (see Builder of the Model rule on page 41).
- 2. Team:** This category is available to allow one of the Team members that exceed in piloting or building skills to participate in a competitive environment and also learn from their Team partner. The Team is considered the Pilot/Builder combination that qualified. Entries will consist of the builder of the model and a pilot of the builder's choice. The pilot may also assist the Builder to help provide guidance and ensure various airworthiness features of construction are included. The builder must be present at the contest to fulfill the definition of a team. In special cases, if the pilot is unable to be present at the Championships due to hardship, the builder may, with pre-approval from the CD, designate another pilot to participate as the builder/pilot combination. Anyone participating in Team Scale as either the pilot or builder can only participate in one Team at the same event. The top 30% in a Team scale category will qualify to fly at the Championships that fall. Team Scale will be judged along with Expert Scale for static and flight judging.
- 3. Advanced:** This category is available for top-level pilots using aircraft that are not governed by the Builder of Model (BOM) rule. This includes purchased, modeler-built, or factory-built scale models including ARF/ARC (almost ready to fly/cover). Judging criteria for both flying and static are identical to Expert and Team Scale events as described in this Competition Guide. Any model used for competition in this category shall not be a past winner in the top ten places of Expert or the top five places of Team Scale at the US Scale Masters Championships. Those competing in Advanced may not compete in Expert at the same contest. However those competing in Advanced may also enter as either the builder or pilot in one Team class. Contestants who place in the top 20% of the class at a regional qualifier shall be qualified for entry in the Advanced Class at the Championships.
- 4. Open:** This category is available only at regional qualifiers as an entry-level class for new and developing scale competitors. Contestants may enter the Open category provided they have not previously competed in Expert, Team Scale, or Advanced. This category does not enforce the Builder of Model (BOM) rule and includes purchased, modeler-built or factory-built scale models including ARF/ARC (almost ready to fly/cover). Contestants who have previously competed in Team scale as a builder may compete in Open as a pilot. Static points will be awarded based on documentation provided. Outline will be worth up to 10 points based on 3 to 5 view drawings that have been published or approved. Color and Markings will be worth up to 10 points and require published drawings, color chips and/or artist’s renditions. Craftsmanship will be worth up to 10 points based on accuracy of construction and extent of detail. All static judging downgrades will be in full-point increments. Flight scoring is identical to Expert, Team, and Advanced Classes. Contestants who place in the top position two years in a row at any regional qualifier in the Open Class must be moved to the Advanced Class described above. Any model used for competition in this category shall not be a past winner in the top ten places of Expert or the top five places of Team Scale at the US Scale Masters Championships.
- 5. Fun Scale:** This category is available at regional qualifiers only. To obtain a “static” score a fun scale contestant would provide some form of documentation proving that his/her entry is an example of a full size man carrying aircraft. Documented evidence will automatically score 5 points for static without any judging of the subject aircraft. If there is no documentation, the static score will be zero. Any scale or semi-scale aircraft is eligible for competition including ARF’s. The only requirement is that the aircraft must resemble an actual full size man-carrying airplane. The contestant will be required to use the flight sheet utilized by Expert, Team and Open class and shall be subject to flight judging as if they were flying in those classes.

U.S. Scale Masters Organization

The U.S. Scale Masters Association has been organized as a non-profit association with a volunteer board of directors and advisory committee that fosters the environment for growth.

National Chairman Bill Hart billhartwestmin@yahoo.com

Sets goals and objectives and oversees all Association functions. Works closely with Directors and Advisory Committee to maximize effectiveness in the organization, regional qualifiers, and grand Championship contests.

Vice Chairman - East Coast Mike Barbee mabarbee@aol.com

Vice Chairman - West Coast Jeff Lovitt jlovitt@sbcglobal.net

Assists National Chairman and other Directors in making decisions for the U.S. Scale Masters Association. Acts in behalf of National Chairman if necessary.

Director of Finance Gary Norton gary.norton@comcast.net

Focal point for all financial activities.

Director of Marketing Curtis Kitteringham Curtis.Kitteringham@va.gov

Shape the image of radio controlled scale aero modeling into that equivalent of a professional sport

Director of Administration Carolyn Van Herk cvanherk@socal.rr.com

Communication hub for routing questions and requests to appropriate Director

Technical & Training Director Chuck Adams at6guy@verizon.net

To design, simplify, and promulgate a consistent judging process while creating and implementing training programs and managing the judge certification process.

Advisory Committee Chairman Jeff Whitney jeff@mds-sf.com

This is an appointed position. Creates and maintains communication networks of active modelers in all regions that reviews and recommends changes to the direction of the U.S. Scale Masters Association.

Advisory Committee: The following individuals currently make up the Scale Masters Advisory Committee appointed by the Advisory Committee Chairman: Jeff Lovitt, Mel Santmyers, Gerry Fingler, Bruce Bender, Scott Foster, Randy Hansen, and Mike Winter.

Web Page: The Scale Masters Association maintains a web site at [HTTP://www.scalemasters.org](http://www.scalemasters.org) for the use of members, competitors and the general modeling community. Information about the Association, events, notices and the Scale Masters Judging Guide are posted on the web site.

Regional Managers: Northwest RM: Roly Worsfold, rolydd@telus.net Mid West RM: Mitch Baker, mdbaker@mdbaker.org; South East RM: Mike Chilson, itsme@mikechilson.com; South Central RM: Lawrence Harville, lawharv@yahoo.com

Additional positions are available; contact USSMA HQ

Advisor to the National Chairman Kent Walters Kentwltrs@aol.com

Special Thanks go to the following for their help in making this edition possible:

Gary Norton, Chuck Adams, Jeff Lovitt and Kent Walters for their excellent editing skills. Thanks to **Jeff Whitney** and the **Advisory Committee** for their advice, persistence, and patience. Thanks to **Michael Peck** for his subtle and gentle leadership and guidance, **Roly & Diane Worsfold** for tracking and mailing out all of the Qualification Notices (Big Job!). Special Thanks goes to our webmaster **Josie Aune, Carolyn VanHerk and Mitch Baker** for the new look and functionality of our website and for keeping all of us together.

Also thanks to you, **our contestants**, who we all work so hard for. Couldn't have done it without you!

Proposals to Change U.S. Scale Masters Competition Guide

This Guide is the result of many years of refinements based on inputs from you, our customers. With this endeavor, we have respectfully taken the position that those things worth doing are worth defining which is what we have attempted to do in this guide. The purpose is not to specifically define each and every instance or possibility like a rulebook as this would be too large in size, rather, to provide clear picture of intent to what the program is all about. This will allow correct decisions to be made as specific questions are brought up. We welcome any comments or suggestions accordingly as we proceed along this path. They may be addressed to:

Bill Hart

U.S. Scale Masters Chairman

9151 Larkspur Drive

Westminster, CA 92683

email: billhartwestmin@yahoo.com

phone: (714) 894-2747

The Scale Masters Board of Directors shall sanction any and all rules governing the contest. Proposals for change to individual rules is acceptable, provided that:

1. The proposal is made in writing, and signed by a past contestant of any Scale Masters contest
2. The proposal is submitted to the Board before October 31st of any year to allow evaluation prior to the publication of the Guide for the following competition year.

Proposals for changes may be sent to the above address.

We, the U.S. Scale Masters team thank you for competing and inspiring others to get involved!



Artwork by Eddie Petrill of Funkshun Graphics

U.S. SCALE MASTERS COMPETITION GUIDE

Section I General Rules

Rules for the U.S. Scale Masters Program are described herein.

1. Scale models are limited to 55 pounds *without* limit to engine displacement. (NOTE: This *priority in weight* rather than engine size is still covered by AMA insurance, similar to FAI rules. Jet turbines may be flown only with a valid “*AMA turbine waiver*” on an individual request basis.)
2. The average of *three best flights* shall be utilized when four or more flight rounds are flown. If only three rounds are flown, the two best will be averaged.
3. Craftsmanship shall be judged no closer than *four feet* distance for static judging.
4. Scale operations are only scored as ***maneuver combinations*** (see page 22) with pilot skill and scale operation score (10 point total) divided accordingly. For example, flaps and retracts may not be used as individual scale operations and would only be scored as part of Overall Realism, unless they are used in the “Slow Speed Dirty Inspection Pass (maneuver combination)”.
5. The only approved mechanical options permitted for a scored flight option are Multi-Engines, Swing or Folding Wings. All others (including scale operations) must be used with a maneuver identified as “maneuver combinations”.
6. The options of *straight flight out, procedure turn, and straight flight back* shall be scored as only *one* flight maneuver or “Procedure Turn”.
7. Takeoff shall *continue* to be scored until 30 feet elevation.
8. The landing will be scored from the time the aircraft enters the *final approach* to the point at which the aircraft sufficiently slows to permit a safe turn from the runway.
9. In strong crosswind situations, it will be up to the discretion of the CD to allow Takeoff and/or Landing as scored maneuvers to be optional. Other maneuvers must be selected to replace take off or landing maneuver should this occur.
10. Static Judges will compare the model to the documentation the contestant has provided. If the documentation is insufficient, the judges have no choice but to judge according to what they have been given by the contestant and their understanding of the process outlined in this Guide (reference page 32)
11. Flight Judges will compare the models flight to the written maneuvers described within this guide, the contestants approved Maneuver Declaration Sheet, or other approved Guides such as current AMA Competition Regulations and/or FAI Sporting Code.
12. Tailskid aircraft will be allowed to attach a non-scale functional tail-wheel for flying off of paved surfaces only. Anti-scuff tape may also be applied to the bottom of the wing tips to protect the covering with no loss in points.
13. There is no provision for a contestant to “refly” any round in competition unless authorized by the CD.
14. A gyro may be used on rudder control only.
15. **Official Score:** The official score shall be the total of Static Points and the average of the three (3) best flight scores when four (4) or more rounds are flown. If only three (3) rounds are flown, the official score shall be the total of Static Points and the average of the two (2) best flight scores. To break a tie, the single best Flight score will be added to the Static score. If this does not break the tie, add the average of the two (2) best Flight scores to the Static score. If this does not break the tie, add the average of the four (4) best Flight scores to the Static score.

SAFETY

Section II Safety

2.1 The importance of safety is the highest priority at any event. A contest director must make himself aware of all possible safety hazards and do his best to prevent any occurrence of any safety violations. It is recommended that a Safety Coordinator be appointed who can focus on the safe operation of model aircraft and be on the lookout for accident prevention during the event. The Safety Coordinator shall conduct the preflight safety inspection and record his findings on the Preflight Safety Checklist form (located on the last section of this Guide). Any contestant refusing to follow recommendations for correcting safety issues found shall be disqualified and not allowed to fly.

The contestant must declare that the model to be flown has had at least 3 consecutive successful flights prior to attempting round one of the competition.

2.2 Runway Safety: All maneuvers not requiring access to the runway to perform shall be placed beyond the far side of the "defined runway" on the *maneuvering line*. This is a notable change from descriptions provided by the AMA rules, which has certain flight maneuvers flown over the middle of the runway. Downgrade for drifting in over the defined runway in performing flight maneuvers will be proportional to severity. For example, a maneuver that violates one half the runway width (up to centerline of runway) will score no better than a five, etc. (This deduction is from the maximum 2.5 points for "placement" and a portion of the 5.0 points for "precision".) Maneuvers requiring access to the runway will include Takeoff, Landing, Touch and Go, as well as Overshoots. For Safety reasons, no exception to these maneuvers will be made unless the C.D. formally announces the exceptions prior to the beginning to the flight round, preferably in the pilots' meeting. The start of an optional Traffic Pattern must also begin beyond the far edge of the defined runway, but will be in alignment to the runway on final approach.

2.3 Deadline Infractions: Crossing the **deadline**, as observed and agreed by the judges, during any part of a flight will incur a warning to the contestant and score a zero for the maneuver being performed (or the previous maneuver if the occurrence is between maneuvers). A repeat crossing disqualifies the flight and the contestant must land immediately.

2.4 Transmitter Control: An impound area for all transmitters shall be set up and strictly enforced. During the contest no one should have a transmitter in his/her possession without a frequency pin. After contest hours, open flying is permitted provided an announcement is made and a designated frequency control person is assigned.

2.5 Pyrotechnics: No pyrotechnics will be permitted at any time.

2.6 Dangerous flying of any sort, or **poor sportsmanship** of any kind, shall be grounds for disqualification of the contestant involved. Contest Director's decision is the final word.

2.7 Weight Limit: Models shall weigh no more than **55 pounds** ready to fly, **including fuel**.

2.8 Metal propellers are not allowed for flying but may be used for static judging.

2.9 Recommended Site Set-Up. Judging stations should be at a minimum of 30 feet from the edge of the active runway. Barriers should be set up to keep spectators out of the pit areas and no closer than 60 feet from the edge of the active runway. Judges stations should be at least 50 feet apart but in line with each other on the judges' deadline. Pilots are to stand 3 to 6 feet on either side of the judges' box and 1.5' behind the deadline. Callers are to stand in an area behind the Pilot. A protective fence or barrier should separate the judges from the engine start up area and from the active runway.

It is recommended that the GPS coordinates for the flying site be posted in several areas around the contest site and also given to the nearest Emergency Medical Response Team office along with the dates of the event in case of emergency.

2.9 Example Site Set Up Diagram. The Grass runway could be on the other side of the hard surface runway if the site doesn't allow what is shown below.

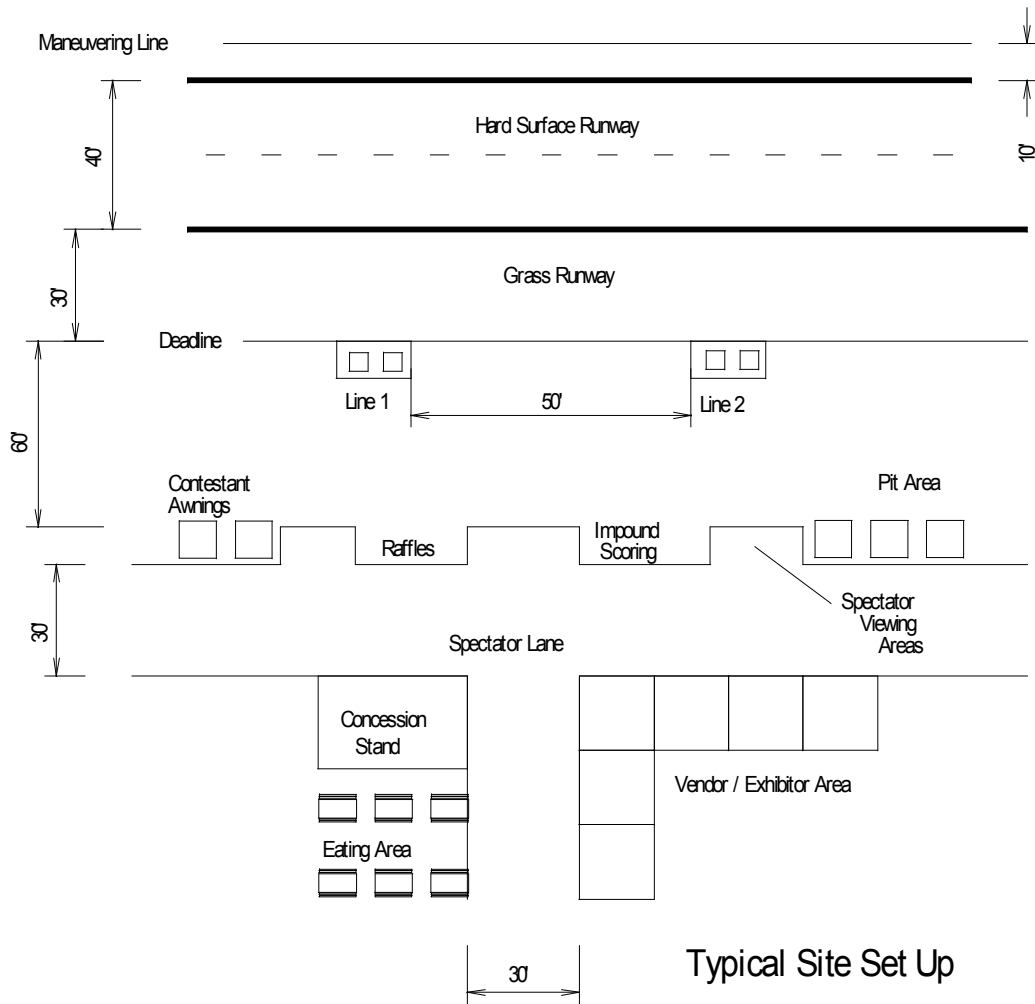

Typical Site Set Up

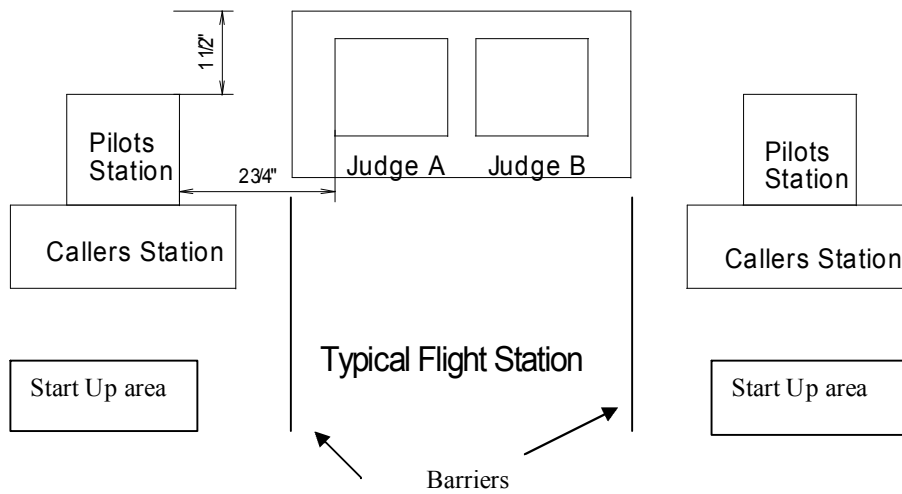

STATIC JUDGING

Section III Static Judging

The static portion of the contest is very important since it makes up a significant portion of your overall score. Good documentation gives you the edge over a similar model with poor documentation. We would like to point out some common frustrations shared by contestants and static judges alike. We all have a favorite airplane that we want to build and fly; however, pick a color scheme that can be documented. Remember it is your choice on what you bring to the contest and Proof of Scale and Color is the contestant's responsibility. For example, if the available documentation for a particular aircraft is not easily obtained or understood, then you might consider another aircraft's paint scheme. Please don't blame the judges for down grading your model if the documentation is poor. Plan ahead and pick documentation that clearly shows outline, color, and markings of the aircraft you intend to model. The ideal situation would be three steps: 1) you decide to compete in the top level of the Masters; 2) you find documentation of the very aircraft you would like to build, and; 3) you build your model to perfectly match the documentation. If you already have an airplane built and you then decide to enter the Masters, all you can do is to try and alter your model to match the documentation. The judges will in turn do the best they can with the information you provide them. Remember...it is your choice of model and documentation, not the judges. Color paint chips for proof of Color will no longer be a requirement but simply one of many optional methods to document Color.

Judging for Outline and Finish-Color-Markings shall be judged at a distance of 15 feet.

Craftsmanship shall be judged from no closer than 4 feet. The static judges shall not examine the models closely prior to the start of static judging. Static scores for Expert and Team class shall be from 0-10 points for each sub-category on the score sheets with the exception of Color, and Landing Gear under Craftsmanship. Color and Craftsmanship Landing Gear shall be 0-5 points each. Category totals are as below. See Figure 10 on page 32 for judging set-up information.

The maximum static score for each category is:

Accuracy to Outline	40 points
Finish-Color-Markings	25 points
Craftsmanship	35 points

Static judging shall take place prior to flight judging. It is recommended that the documentation package be contained in a 3-ring binder so that each section can be removed and presented to the respective judge to allow simultaneous judging. The static judging process starts after the contestant places the various documentation pages in the judges' box on the table arranged according to the judge function, e.g. one three-view set is placed in the box labeled "Outline Judge" and another set is placed in the Finish-Color-Markings box. Color photos and/or color chips are also placed in a box labeled "Color-Markings", etc. A box will also be provided for Craftsmanship related documentation. The contestant then places the model on the judging stand/table and points it straight at the Outline judge. The Outline judge sets the pace and calls the position he wants the aircraft displayed in, starting with the front, head on view. The Craftsmanship judge walks around the aircraft, no closer than 4 feet, but does not talk to the contestant. If he has a question that needs clarification, he may refer to the photo documentation that the Finish-Color & Markings judge has, or the additional separate pages for Craftsmanship provided by the contestant. When the judges are ready, they will ask the contestant to position the model as necessary. The viewing order is as follows:

1. Straight (head on) view
2. Side View (the side that matches the documentation)
3. Top View
4. Bottom View

Feedback comments from the judges can be written on the generic 3-view diagram on the score sheets or extra copies of the outline drawings if they are provided (1 for each judge type). The judge will highlight the area of mismatch and write in a couple of key words that denote the error if time permits.

Use of transmitter to operate mechanical scale operations during static judging will not be allowed. Cockpit and cabin interiors, excepting those visible items called out in 3.2 Accuracy of Outline, or the interior of landing gear wheel wells, even if partially visible from the judging distances are not to be considered in scoring the model. All other visible features will be judged. Simultaneous judging is a process where all three static judges judge the aircraft at the same time. For every minute the aircraft is in front of the judges being judged, 3 minutes of judging time elapses.

3.1 Documentation: A maximum of eight (8) pages equivalent in size to 8.5 x 11 inch paper is allowed, except the three or more view published or approved* outline drawings may be on larger size sheets (max size 11x17). The outline drawings will count as one page of the eight permitted. If a conflict exists between outline drawings and submitted photographs, the photos shall take precedence. Extra 3-views for judges' feedback, the cover page, index and signed Builder of the Model Declaration statement will not count toward the 8 maximum pages. Emphasis is placed on the quality of the documentation presented to the judges. Poor or hard to interpret drawings make it difficult for judges to compare to the model will not enable a good score. Many examples of excellent models that score poorly due to poor quality documentation (or not enough) happen each year. Be careful not to fall into the trap of "less is better" as the judges must have adequate documentation to compare each item they see on the model to some reference shown on the presented documentation (including views of the aircraft's underside).

.1 The Ideal Documentation Package would Contain;

- Cover Page and/or index page
- 3 or more view drawing(s) showing the aircraft outlines, color scheme and markings location. Separate drawing(s) may be used to show outline and color/markings scheme. Three ring binders work well for being able to quickly separate outline drawings from color and marking references such that each judge can have their own document to work with for Expert and Team class..
- Photographs of the actual aircraft being modeled
- Paint chips or other proof of color for each color used
- Signed Builder of the Model **Declaration** statement (*see page 41*) for Expert and Team class.

*Your regional AMA Scale Contest Board member can approve, by his signature, documentation that may not be from a published source. See Model Aviation Magazine for name of your CBM.

.2 The flying spinner must be presented to static judges for comparison if it replaces the static spinner in flight. Any exposed flight "droppable" must also be presented including those that may be different from static display examples. No changes may be made between static judging and flying which alter the scale appearance except:

- a) Propeller. A flying propeller of any diameter and color may be substituted for a scale or static prop for flight.
- b) Radio antenna of any type may be added.
- c) Takeoff dollies may be used for models of seaplanes or flying boats in the absence of suitable water conditions. If dollies are used they must not remain attached to the model in flight. Deviations from scale appearance through the inclusion of permanently mounted recessed wheels, skids, or similar devices, if visible, result in downgrades in both static outline

- judging and overall realism during flight judging. Takeoffs or landing of such aircraft will be judged by the same criteria of Precision, Placement, and Realism except that the surface area such as rough grass may disrupt the Realism portion of the score of which the judges are to ignore for this situation only. The contestant may choose another optional maneuver to take the place of take off or landing for seaplanes if desired.
- d) If bombs, rockets, drop tanks, etc., are to be dropped or released during flight, they must be in place at the time of static judging. A scale "droppable" may be replaced during the flying portion of the contest as long as they are of the same size, shape, and color as those presented during static judging. Static judges will make a note on the static-judging sheet of all observed "droppable" stores in place on the model at the time of static judging.
 - e) Pitot tubes projecting from the wing or fuselage should be removed for flying without scoring penalty (unless damage to the model would be incurred); however these must be installed during static judging for optimum static score.
 - f) Subjects that provide no opportunity to conceal the engine or exhaust system (such as water cooled in-line engines like the Spitfire, P-39, etc.) will not be downgraded by the **outline judge** if: **1)** part of the model engine or exhaust system is exposed or: **2)** non scale openings that facilitate model engine cooling are visible. However, a higher Craftsmanship score may be awarded to those who conceal the engine and exhaust system as compared to those who don't.
 - g) Dummy fan blades in jets or turboprops may be used in the intake and exhaust regions where applicable during static judging and removed prior to flight with no scoring penalty. No plugs may be used to obscure these regions. Static presentation shall be as if the aircraft were ready for flight. No other changes may be made to intake or exhaust openings between static judging and flight. Documentation details of these regions are the responsibility of the contestant for static judging.
 - h) No pilot(s) need be in the cockpit during static judging, but must be in place for flight. If no pilot(s) are properly located in the cockpit during the flight, a downgrade in realism shall be given (see item 4d on page 39 for further details)

3.2 Accuracy of Outline:

Outline consists of all major geometry features (location and proportion) of the full size aircraft including features of the cockpit or cabin that may be visible from the side view such as headrests, gun sights, etc. Other major geometric features, that may be located inside of the aircraft's profile, include control surfaces, wheel wells, exhaust stacks, pods, air louvers, gun troughs, windows, and doors. The Outline judge will compare the outline profiles from the provided three-or-more view drawings (from an approved source) with the features on the model that include the outline of landing gear, tail wheel outline, and other profile features that show on the drawings. Any surface detail features of the aircraft shall NOT be considered when scoring Outline features such as panel lines, inspection panel doors, and methods of hinging, connector detail, or any other feature listed for Craftsmanship in 10.3 herein to avoid double jeopardy. If no three-or-more view drawing exists, photos of the actual aircraft modeled may be used that are sufficient to show the outlines of the aircraft in side, front, and plan (top) view details. For optimum score, drawing/s and or photographs used for 3-views need to be taken from 90 degree angles to the side, front and top view to show true outline. Landing gear shall be considered only for size, angles and outline. Additional items such as panel lines, brake lines, jack points, fill ports, and tie-down hooks or any other detail features described under paragraph 10.3 for "Criteria for Craftsmanship" shall only be considered under that separate scoring category to avoid double jeopardy. Computer generated drawings or computer printed photos will be allowed if they have **not** been altered from their original published form. If any alterations have been made from published sources to reflect greater accuracy they must be

approved by a Scale Board Member or other recognized authority with supporting documentation for those changes made. If no proof of Outline is presented, no points can be awarded for Accuracy of Outline (see criteria for Accuracy of Outline in paragraph 10.1).

Notice the difference in outlines in the example:
Imagine one being the model and the other being
the documentation

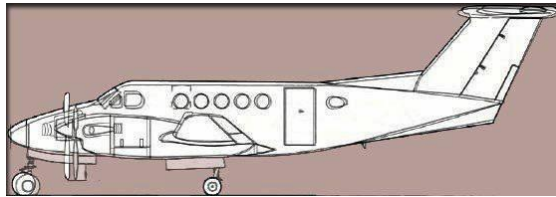

3.3 Finish, Color and Markings

The intent of this section is to verify the contestant has properly researched the full-size aircraft to prove that the model they are presenting matches the full-size aircraft. The contestant may provide photographs, published artist conceptions, or published photos that show color, finish, and marking details of the actual aircraft being modeled. Proof of color may also be in the form of either; paint chips from approved sources such as Federal Standard 595, FTE Color Guide, Monogram Color Guide, factory color chips or other published color documentation sources. Your AMA Scale Board Member can approve unpublished color documentation samples with supporting written documentation. Some vintage aircraft were flying before color film existed so modelers must rely on artist conceptions, black and white photos, or colored line drawings of the subject to document color and markings. If black and white drawings and/or photos are used, a description from an approved source of the colors used for the aircraft color and markings and their location on the aircraft must be included in the documentation package. For subjects in which it is difficult or impossible to document more than one side or view of an aircraft, there shall be NO penalty for failure to show the other side or bottom of the aircraft. See criteria on page 37.

For the judge to determine location, color, size, and graphic content, documentation of markings specific to the aircraft being modeled need to be provided. However the judging of color in these markings will be included only in the score provided for overall Color described previously (5 point maximum) to ensure the color score is not over emphasized. See Static Judging score sheets at the end of this Guide for Finish (10 points), Colors (5 points), and Markings (10 points).

If no proof of Finish, Color, and/or Markings accompanies the model, no points can be awarded for Finish, Color, and/or Markings section of the score sheet.

3.4 Craftsmanship consists of judging the quality of workmanship on the model that is being presented. The Craftsmanship judge will judge no closer than four feet distance from the model surface to still permit definitive scoring of details. The Craftsmanship judge should consult with the Outline and Finish judge to ensure an item is not double downgraded (once by the Outline or Finish judge and once by the Craftsmanship judge). The quality of panel lines, brake lines, jack points, fill ports, inspection panels, tie-down hooks or any other scale detail feature will be considered by the Craftsmanship judge. Items such as non-scale exposed control horns would be a source of downgrade for craftsmanship.

Craftsmanship will be separately itemized on the score sheets for wings (10 points), fuselage (10 points), and Tail Group (or their equivalent by design) (10 points) and Landing Gear (5 points). Emphasis is placed on how well the modeler created the illusion of scale detail on the model as compared to the documentation (NOTE: Close proximity photos or other documentation of the full-size aircraft may be beneficial to include for emphasizing applicable subtle features. Published 3 views may lack sufficient detail that may otherwise benefit a contestant's craftsmanship effort). See criteria for Craftsmanship on page 38.

FLIGHT JUDGING

Section IV Flight Judging

The intent of the flying portion of the contest is to determine the pilot's ability to match the model aircraft's flight performance to that of the full-size aircraft in the most realistic manner possible. The U.S. Scale Masters has emphasized this in the creation of maneuver combinations where mechanical operations must be combined with a flying maneuver to enhance realism. It is recommended that a theme or mission be established in choosing flight maneuvers so the flight routine's order is easier to track and is more pleasing to watch. At the Championships, there is a special award given to the contestant who performs the most realistic flight routine as voted on by the flight judges. The emphasis will be placed on scale realism, so be aware that your chosen aircraft type will determine your maneuver's parameters such as speed for correct attitudes, geometry, and positioning with respect to the judges' centerline. Contestants should indicate if their aircraft type is designated either Aerobatic capable or Non-Aerobatic by checking the appropriate box on the flight score sheet. To document maneuvers not contained in this guide or AMA and FAI Competition Regulations a Maneuver Declaration Sheet should be filled out by the contestant, signed by the Contest Director and presented to the judges before each flight.

4.1 The contestant is encouraged to brief the flight judges when handing them the score sheets by going over each maneuver and explaining exactly what the judges are to expect. This is the opportunity to clarify the particular maneuvers the contestant has chosen. The information provided to the judges is what they will inspect for. If the contestant says nothing, the judges have no choice but to judge according to what they understand a maneuver should look like based on this guide and other guides such as AMA and FAI Competition Guides.

4.2 The Flight Judge will not downgrade items that are beyond the pilot's control such as when a tailskid aircraft is slowing down from a landing, at the point where the model *takes control* and turns into the prevailing winds. The judge will stop judging at the point the model takes over and calculate the score. This is also true during wind conditions, which may adversely affect the aircraft. The judges will make every attempt to be familiar with areas of the flying field that exhibit these unstable air conditions and take this into consideration in scoring.

4.3 Tailskid aircraft will be allowed to attach a non-scale functional tail wheel and scuff-plates or wing-tip skids for flying off of paved surfaces only.

4.4 Each maneuver will start with a score of 10 points and the flight judge will deduct for errors noted during the execution of the maneuver. Errors will include mismatches noticed in precision, placement, and realism for each maneuver.

4.5 Judges are to ***remain independent*** in their scoring and are not expected to arrive at the same maneuver score. Judges are not allowed to communicate or check with each other in routine scoring during flight and are encouraged to sit at a sufficient distance from one another to maintain the integrity of statistically independent judging for subsequent score averaging.

However if a 0 is given for a score, flight judges ***must*** confer, and in this case identical scores are required. At the conclusion of the flight, judges will confer on the Overall Flight Realism qualities and again need ***not*** award identical scores.

4.6 The following are examples of mandatory zero scores for specific maneuvers or sequence of maneuvers:

- .1 Crossing the deadline at any time during flight
(0 for the maneuver being performed or for the previous maneuver)
- .2 Maneuver(s) performed out of sequence
(0 for the skipped maneuver(s) but judge the rest normally)
- .3 Touching the model after any maneuver starts such as when restarting an engine after the takeoff roll has begun (10 point loss), see 9.5 for engine restarts (unless directed to do so by the CD or Air Boss).
- .4 Model flips over on its back on landing (except tailskid aircraft, see 5.4.2 on page 18)

.5 Use of similar or redundant flight options for maneuvers or scale operations in maneuver combinations, e.g. Roll, then Military Roll, then 2 point Roll, etc.

.6 If the aircraft becomes airborne with flying speed and is forced to land immediately or anytime thereafter before the flight is complete, any maneuvers not performed before landing have effectively been skipped and will be scored zero as in item 4.6.2 above.

4.7 Replacement of damaged parts is limited to props, spinners, wheels, tires, landing gear units, cowls, canopy, tail wheel units, antenna, flying wires, and struts as long as the replacements are of the same size, shape and color as those on the model when it was presented for static judging. If a flying spinner cannot be replaced or safely repaired, the Contest Director may allow the aircraft to continue to fly in competition (without the spinner), however, the flight judges will make a 2 point reduction to the continuity of flight portion of the overall flight realism score for each round that the aircraft flies without the spinner. Any other damaged components will need to be repaired and retained as original equipment by the modeler. Damaged aircraft which have been repaired may require a new safety inspection before being allowed to re-enter competition.

4.8 With the exception of electric motors and turbine aircraft, the engine must be equipped with an effective muffler or silencer to limit noise output in flight. Tuned pipes are considered silencers.

4.9 Maneuver scoring content: Maneuvers and *maneuver combinations* with scale operation elements will be scored for three basic content considerations as listed below. These are similar to those found in the AMA Competition Regulations Rules Governing Model Aviation Competition in the United States, except provision is now made for *maneuver combinations* as further explained in section 7. The three contents are:

Maximum of 5.0 points for **Precision**.

Maximum of 2.5 points for **Placement**.

Maximum of 2.5 points for **Realism** for each maneuver.

Each of the contents is scored to the nearest ½ point. A maneuver starts at 10 and then deductions occur. A *maneuver combination* is primarily scored with equal emphasis between the maneuver and the scale operation feature. This is further detailed as follows:

4.9.1 Precision Content (5 pts.): The pilot's ability to perform the defined maneuver geometry, and when applicable, the Precision of scale operation features within a *maneuver combination*.

.1 A *maneuver combination's* precision content will be equally divided between maneuver and scale operation (or maximum of 2.5 points each). Should scale operational feature(s) fail to operate or deploy within a *maneuver combination* in a realistic and timely manner due to either mechanical malfunction or pilot error within a *maneuver combination*, the result will be a 50% downgrade in the score for "Precision".

.2 Precision of flaps, slats, and retracts is demonstrated by their prototypical operation and will only be judged on the pilot's Precision in the "Overall Flight Realism" score. They may also be judged as part of the "Slow Speed Dirty Inspection Pass" described in 8.5 as a maneuver combination.

4.9.2 Placement Content (2.5 points.): Most in-flight maneuvers (including those with a "droppable") will optimally be placed directly in front of the judges (judges' centerline) on the maneuvering line. This will typically be at 10 to 50 feet *beyond* the far side of the defined runway area for fly-by type maneuvers. There are times when the contestant will be allowed to offset maneuver to either side of judging center as long as the contestant informs the judges before the maneuver, otherwise the judges will have to default to the judges' centerline for placement. Judges may request maneuvers be offset to aid in visibility. The contestant is not

obligated to offset the maneuver if asked, but he should be aware that if the judges cannot adequately view his maneuver it will be difficult to score. A *maneuver combination's* placement content will be approximately divided between maneuver and scale operations.

- .1 Maneuvers with horizontal symmetry (Cuban Eight, Loop, Roll, Figure 8, etc.) should have their midpoints on the judges' centerline with equal distance on each side for optimal score.
- .2 Some maneuvers due to their asymmetry are offset from judging center for best viewing, such as a Stall Turn or Wingover. Also the Procedure Turn is positioned in the Scale Masters Program where the initial 90 degree turn away from the runway begins *before* reaching judging center, and the remaining 270 degree turn starts at judging center to the left or right.
- .3 Although the placement of a maneuver normally represents only 2.5 points content, a greater penalty deduction will be imposed in the interest of safety when maneuvers are performed unnecessarily close to the flight line (over the runway) as described in "Runway Safety and Deadline Infractions" of this Guide.
- .4 Optimum placement of bomb drops will be defined as the point of **impact** in front of the judges at the far side of the defined runway. When discussed with judges' prior to flight, the maneuver may be performed slightly to the left or right of the judges' centerline for best viewing. Parachute or empty tank drops will be scored for optimum placement as point of **release** rather than impact, since wind conditions may unpredictably affect point of landing.
- .5 The optimum placement of flaps, slats, and retracts deployment is only included in Overall Flight Realism "Continuity" unless the optional *maneuver combination* of Slow Speed Dirty Inspection Pass is also selected.

4.9.3 Realism Content (2.5 pts.):

The realism content of the score is based upon the pilot's skill in performing maneuvers with the model like the full-size aircraft in actual flight. The size, shape, and speed of aerobatic maneuvers performed by a contestant should reflect the capabilities of the full-size prototype. For example, it would be expected that a loop performed by a J-3 Cub would be smaller in diameter and egg-shaped compared to a loop of a P-51 Mustang if both models were of the same scale. The speed at which each maneuver is performed should also reflect the capabilities of the prototype. Consideration should also be given to throttle position during flight. In many full-scale aircraft, power must be reduced on the descent portion of that maneuver. Execution of such maneuvers by a model at a constant full throttle setting should be downgraded in realism portion. A particular maneuver may be downgraded for realism content if it is apparent it exceeded the performance capabilities of its full-size counterpart. Maneuvers that have been classified **only** for non-aerobatic aircraft will still be judged for all maneuver contents without downgrade for all aircraft. However, the "Overall Flight Realism" score may be penalized if such maneuvers were chosen as options by high-performance aircraft.

For *maneuver combinations* the realism score content will be appropriately divided between maneuvers and scale operations. See section 7 for maneuver combination examples.

- .1 Consider the stability or "smoothness" aspect of each maneuver as well as the power management (throttle) expected for that specific maneuver of the model compared to its full-size counterpart. Both of these considerations will be influenced by aircraft design and wind conditions. Since slow, lightweight aircraft will be much *more visibly influenced by wind* than fast heavier aircraft, wind conditions should be taken into account during judging.
- .2 Maneuvers should appear realistic in scale size of performance (site and conditions permitting). Attitude, bank angle and g-loading appearance through turns should be consistent with those generally observed in the full-size. With scale-size maneuvers, these prototypical

attitude features are achieved through use of an optimum speed relationship to the full-size aircraft. Also see Definitions section later in this Guide for Optimum Speed.

.3 The realism content of a *maneuver combination* will also have approximately the same emphasis between the maneuver and the accompanying scale operation feature(s) regarding realistic motion or other intended activity displayed for realism. For a "droppable," this will include the manner in which the droppable was secured and carried in flight as well the trajectory likeness to that of the full size.

LIST OF MANDATORY MANEUVERS

Section V Mandatory Maneuvers

The contestant must perform 5 mandatory maneuvers (includes Overall Flight Realism) and 5 optional maneuvers unless the CD indicates the Takeoff and Landing may be replaced with other options. They can be presented in any order except Flight Realism, which will be scored at the end of the flight. Models of pure seaplanes or other aircraft that do not have wheeled landing gear may select two other optional maneuvers in place of Takeoff and Landing as scored maneuvers.

5.1 Takeoff

Judges are to evaluate:

- Roll out straight and down the indicated centerline (see exception for "tail skid" aircraft).
- Gentle lift off, wings level, tracking straight, climb out angle consistent with prototype.

NOTE: The CD will announce at the pilots meeting if there will be exceptions for takeoff or landing becoming optional for various aircraft.

- Gentle and steady climb out to 30 feet altitude
- Observe mechanical operations, i.e. retracts, gear door sequencing, flaps (when applicable) for Overall Flight Realism.

Judging for Take off and Landing scores will not consider wheels off or on runway location regarding Judges Centerline (some contestants felt lifting off at Judges Centerline was not possible to practice due to their club's short field).

.1 The takeoff maneuver shall be scored after heading position is initially established with a brief hesitation near the lengthwise centerline of the active runway. (Exception: When safe operation permits, tail-skid aircraft can establish a heading more into the wind so the judges need to establish an imaginary centerline based on the initial path started at takeoff). This new established heading *shall not be directed toward the judges or deadline*. A full stop may be made, but is not required between the end of the taxi and the beginning of takeoff. The contestant must announce that "takeoff maneuver is starting now" prior to starting the takeoff roll. For optimum scoring, the roll must be parallel to, and in close proximity to lengthwise centerline of the runway. The roll distance and tracking prior to lift-off should be realistic in scale to that of the full-size aircraft (runway permitting). During climb out, the wings should remain reasonably level with original heading maintained. The takeoff optimum heading and prototypical ascent angle should be maintained to an elevation of at least 30 feet to complete the maneuver prior to making the initial turn away from the flight line. For optimum "Continuity" score in Overall Flight Realism if the prototypical aircraft design has retractable gear, gear retraction should be initiated sufficiently soon after lift off to allow completion (or near completion) of retraction prior to initial turn away from the flight line for optimum "Continuity" score in Overall Flight Realism. If the gear fails to retract and remain down during flight, a severe downgrade will apply to Overall Flight Realism "Options" and "Continuity". Flaps and slats (if applicable) may be used during the takeoff maneuver, but are not required for most available runway lengths. Retracts, flaps or slats shall not dilute any of the scoring contents for pilot Precision, Placement, and Realism in takeoff. Also see item 9.7 for Aborted Takeoffs.

.2 In strong crosswind conditions, it will be the discretion of the CD to make Takeoff an optionally scored maneuver that would then require replacement with another maneuver.

5.2 Figure Eight

Judges are to evaluate:

- Maneuver called at 45 degrees from Judges' Centerline (left or right of judges)
- Bank angle typical of full-size aircraft at speed
- Crossover points on Judges' Centerline (directly in front of Judges)
- Crossover points at same altitude and location
- Symmetry same, left circle same size/diameter as right circle
- Exit altitude same as entry altitude

Perhaps more than any other maneuver, the horizontal figure 8 best reveals how well a pilot can position and control the aircraft with a prototypical attitude and precision over a large horizontal area in various environmental conditions. The maneuver starts with a straight and level entry. It can be flown from either direction depending on the wind. Usually it is flown starting into the wind. At a 45-degree angle to the judges the contestant calls, "maneuver beginning now." He then begins a 90 degree turn away from the judges followed by a 360 degree turn in the opposite direction, and then a 270 degree turn back toward judging center and completes with a straight and level fly past calling the "maneuver complete" at the judges' centerline. The prototypical bank angle used during the figure eight is anticipated to vary in windy conditions to maintain a figure eight pattern with respect to the ground and judges. Be aware that an optical illusion occurs, as the aircraft flies away from the judges as the aircraft, if altitude is perfectly maintained, will appear to lose altitude. Experienced pilots understand this and overcome the urge to climb on the backside, that otherwise would place the aircraft higher than it should be when it comes back around.

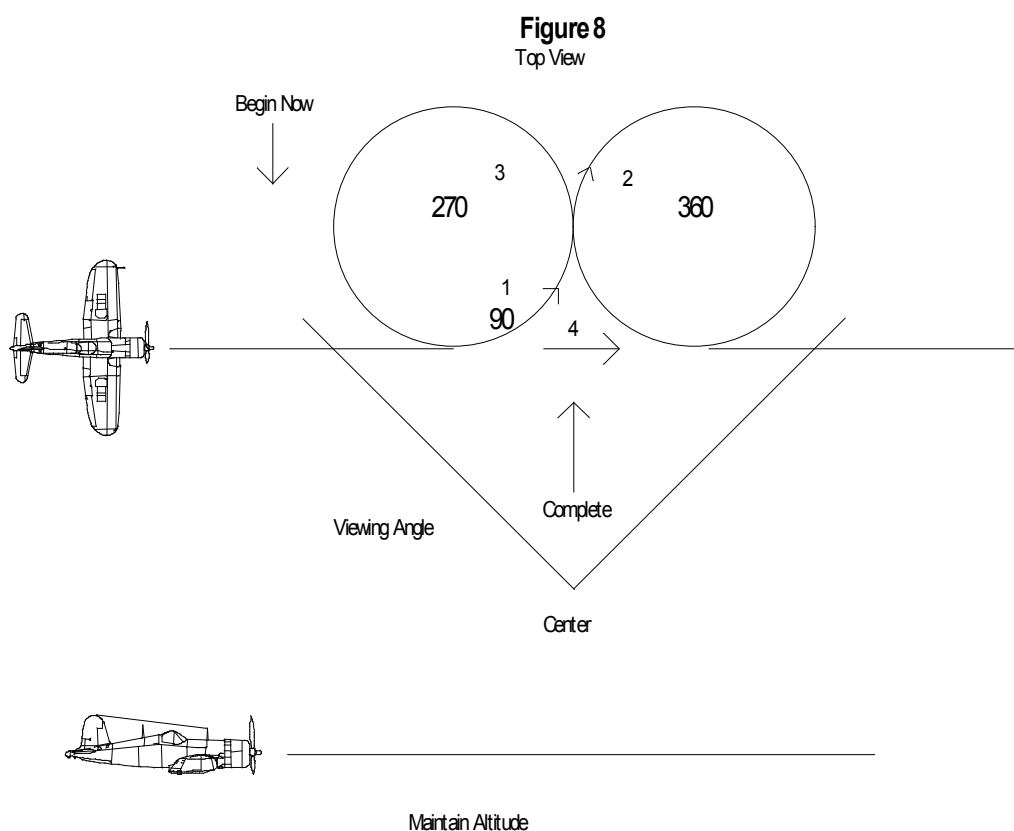

5.3 Fly Past

Judges are to evaluate:

- Direction is same as take off (into the wind)
- Altitude between 10 and 20 feet
- Heading is straight and tracks down the maneuvering line
- Maintains constant altitude
- Equal distance on Judges' Centerline, minimum 150 feet to left and right

The mandatory 10 to 20 foot elevation fly-past will be centered in front of the judges and located over the maneuvering line (see Definitions on page 40). Direction will be the same as designated takeoff unless otherwise specified by the CD or Air Boss. Downgrading will also start occurring if the maneuver is too far out beyond the maneuvering line, or over the defined runway. For optimum score, the maneuver should track straight and level over the maneuvering line for at least 300 feet (not 5 seconds as AMA describes). Allowances shall be made for any aircraft for slight corrections due to gusty-wind conditions. No *maneuver combination* can be included with this maneuver.

5.4 Landing

Judges are to evaluate:

- Observe mechanical operations, i.e., slats, retracts, partial flaps on base leg, full flaps on final (Overall Flight Realism)
- Pilot calls maneuver when turning to final
- Wings level, gentle glide angle, constant rate of descent, tracks on runway centerline on rollout.

NOTE: The CD will announce at the pilots meeting if there will be exceptions for takeoff or landing becoming optional for various aircraft.

- Smooth flare, gentle contact with ground both wheels simultaneously, minimal bounce on touchdown
- Straight roll out, down runway centerline (see exception for "tail skid" aircraft).
- Slows to taxi speed before turning

5.4.1 The Landing maneuver will be scored from the time the aircraft enters the final approach to landing.

.2 For optimum scoring of any landing, the roll out must be parallel to, and in close proximity of the lengthwise centerline of the runway. Tailskid aircraft are anticipated to experience visible corrections for crosswinds. Low speed aircraft such as WW-1 and civilian types like the J-3 Cub are permitted a flare and touchdown that may be directed more into the wind after an aligned approach. In any case their speed and momentum in roll out shall not be allowed to produce a safety hazard or deadline infraction. All other placement criteria apply. Bounces or deviations in described optimum roll out alignment will be downgraded depending on severity of applicable skill contents. Uncontrolled premature turns will similarly be downgraded. "Nose-overs" will be downgraded depending on severity. If "vintage prototypical" the downgrade will be slight, however a complete "nose-over" onto the back will score zero for skill (precision) and realism content features (placement may still be scored). A touchdown or roll out into any area outside of the defined runway will only be downgraded depending on severity, or scored entirely *zero* for the maneuver on a *deadline infraction*. Such downgrades will not be given for short runway facilities where roll out carries the aircraft beyond the end of the runway and touchdown and roll out commenced in the first half of the runway. If the aircraft touches down in the latter half of the available runway and then rolls off the defined runway, all applicable

contents will be downgraded accordingly. As stated in “Maneuver Scoring Content,” skill-related precision and placement may be combined in scoring emphasis for this placement-critical maneuver. The judging of roll out and overall landing maneuver is not complete until the aircraft has sufficiently slowed to permit a safe, controlled taxi from the active portion of the runway. Also see item 9.7 for Takeoff and Landing Aborts.

.3 Scale operational features affecting landing can be complex in many aircraft (for past as well as present scoring methods). Some of them will be described as part of Overall Flight Realism in the following section 5.5, but others may be new. These judging considerations are as follows:

.4 If flaps, slats, and/or retracts are prototypical features of the aircraft, they must be properly deployed prior to landing for optimum “Overall Flight Realism” qualities. In strong wind conditions the amount of flaps and /or slats may be reduced but not eliminated.

.5 Flaps, slats, and retracts will not influence or share in the scoring content expected for landing. However their operation will influence the “Overall Flight Realism” score. Wheel brakes may be used within or after the landing maneuver, but will also be primarily judged in “Overall Flight Realism” for optimum judging.

.6 If a landing gear failure occurs due to inadequate pilot precision or realism in “flare” the landing will be downgraded accordingly. If a “belly landing” is performed skillfully with a smooth touchdown and accurate placement after a gear malfunction during or prior to deployment, the landing may still be scored “optimally” in all of its content features, but not in Overall Flight Realism. As will be described in the next section for Overall Flight Realism, the scale operation “Option” mechanical precision or “Continuity” content for gear, flaps, and slats is in Overall Flight Realism and are not a content element to the landing maneuver. (NOTE: Calling an emergency landing will help alert the judges to score the landing accordingly, but it will not save optimum points for Overall Flight Realism score.)

.7 Scale operation of a drogue chute/s deployed in a timely and realistic manner during the landing roll out shall be scored as a **maneuver combination**. This **maneuver combination** of “landing with drogue chute” will partially share the precision content in piloting skill with an accompanying scale operation feature described in “Maneuver Scoring Content”.

.8 Inclusion of a drogue chute (or chutes) for optimizing Overall Flight Realism “Options” in the landing maneuver will be dictated by prototypical roll out and the “scale-length runway” facilities available. No downgrade in score will occur for not selecting the drogue chute option, if well placed landings can be executed on longer runway facilities. The incentive for the use of drogue chutes(s) in modeling will therefore be the same as that in full scale.

.9 In strong crosswind conditions, it will be the discretion of the CD to make Landing an optionally scored maneuver that would then require replacement with another maneuver.

.10 Emergency Landing: In the event of a mechanical failure (engine out, failure of retractable landing gear to extend), the pilot may elect to declare an emergency landing. Such landing shall be substantially downgraded in realism content, but will be scored “optimally” in placement and precision content if the pilot calls out “Emergency Landing” to the flight judges. Also see 5.4.6

5.5 Overall Flight Realism

Judges are to evaluate:

- Model performs smooth transitions through each axis (roll, pitch, and yaw) consistently throughout the entire flight (including in-between maneuvers)
- Bank angles consistent with full-size aircraft
- G-loading consistent with full-size aircraft
- Management of power appropriate with performed maneuvers
- Chosen maneuvers consistent with full-size aircraft’s capabilities

The **Overall Flight Realism** score shall be an objective summary based on three fundamental questions outlined in the following. A quick summary for judging or “policing” Overall Flight Realism can perhaps be remembered best as **COP** or Continuity, Options, and Power management. Scoring will be 2.5, 5.0, and 2.5 points respectively with Options having the greatest emphasis for potential deficiencies. Also see “Flight Realism and Score Sheet Review” in this Guide.

5.5.1 Continuity of Flight (2.5 pts.): Has the pilot demonstrated a flight performed with realistic continuity, from the moment the “show starts” as the aircraft taxis out to the time it taxis back?

.1 This shall primarily include how well the aircraft maintains a general realistic appearance on the ground and in the air before, between, or after selected maneuvers. Continuity includes taxi, airborne turnarounds, altitude, smoothness or stability, etc. except when such features are included in defined listed options such as Traffic Pattern, Procedure Turn, etc. It also includes takeoff and landing if not listed as part of scored options as ruled by the CD. When any maneuver option listed for score is started, the applicable deduction(s) will apply to that specific maneuver-realism content and not the Overall Flight Realism “continuity”. (NOTE: Any unrealistic actions achieved from flaps, slats, or retracts due to poor timing will be deducted in Overall Flight Realism for continuity, except when used for the optional scored *maneuver combination* of Slow Speed Inspection Pass.)

.2 Trim passes are permitted without deduction to continuity.

.3 If the aircraft design and vintage permits, it should taxi to and from the runway under its own power (with reference to the judging area) for optimum consideration in scoring the basic continuity to overall Flight Realism. Exceptions will be granted for aircraft with conventional gear and tailskids or float planes with removable “dollies” if they remain under power from time of initial transport to the runway through the final pickup or transport back.

.4 Taxi anomalies to and from the runway due to excessive wind or ground conditions are also accepted without deduction to the continuity portion of realism. These may include manually correcting or carrying the aircraft to or from the runway after such wind or ground conditions have become evident to the flight judges or have been announced by the CD. If conditions are **not** a factor for skipping or avoiding an unassisted taxi for applicable aircraft or, if **any** aircraft requires an engine restart after initially departing the immediate judging area, a 0.5 point deduction applies to flight realism for the departure. The 0.5 point deduction may occur again for a repeat occurrence after landing and return. The clock will not be extended for engine restarts. See “Time Limit and Official Delays” for exceptions caused by traffic.

5.5.2 Options Selected or Demonstrated (5.0 pts.): Have the notable prototypical characteristic features of the aircraft been well selected and demonstrated for its intended design mission by choice in Flight Maneuvers and complementing Scale Operations?

.1 The applicable scale operations of retractable gear, flaps, and slats shall primarily be inspected in flight for demonstrating mechanical precision in form-fit-function of operation. This also includes the prototypical gear retraction, secured stowage qualities, and realistic mechanical deployment prior to entering the defined landing maneuver. If there is question of these qualities in flight that prevents accurate scoring, judge(s) may also request that these features be demonstrated on the ground **after** the flight. This may also include inspection of other basic control features to assure they are operable such as ailerons, elevator and rudder when such prototypical features are also in question.

.2 If a model does not have the notable characteristic design features of the full-size aircraft (such as retracts or flaps) or if they fail to operate when required in realistic flight, a corresponding downgrade will be made to the Overall Flight Realism Options such as a 4 to 5 point deduction.

.3 If flaps, slats, and retracts are used with the Slow Speed Inspection Pass the maneuver shall also be scored for precision for these scale operational content features per *maneuver combinations*.

.4 Aircraft entries that are indeed rated non-aerobatic must be indicated on the flight sheet checkbox. Similar to FAA practices, the Masters considers an airplane non-aerobatic when it is rated *not* to exceed 60-degree bank angles and 30-degree pitch angles.

5.5.3 Power Management (2.5 pts.): Has skill in throttle and power management been demonstrated? Power variations are anticipated to fly an aircraft at moderate speeds in interim flight for turnarounds compared to other fast or slow speeds applicable to the maneuvers performed. Consider that many early vintage (WW1) aircraft were not able to throttle in the conventional sense. Also determine if an idle control (for all prototypical engine arrangements) is adequate to permit a realistic, safe taxi and landing.

Aerobatic aircraft should adequately reflect power capability in engine selection, particularly when vertical maneuver options are performed. Scoring of throttle management skill should be included in Overall Flight Realism (see definition section for optimum speed for flight realism as defined within this Guide in the Definitions section on page 40).

MECHANICAL OPTIONS

Section VI Mechanical Options

Mechanical Options will be evaluated continuously in mechanical performance throughout the flight.

6.1 Multi-engines: The mechanical option of multi-engines will be judged entirely for its mechanical fidelity in configuration and size to duplicate the performance of its full-size counterpart. Emphasis on desired mechanical-operational similarity and reliability as it may affect flight performance will be judged a score of 10 only if all engines continue to run smoothly, reliably, and in reasonable synchronization throughout the flight.

.1 If one (or more) engines quit(s) before the flight has concluded, a downgrade will be given which is proportional to that part of the engine arrangement, which did not continue to run. For example, if one engine quits in flight on a twin-engine configuration, a score of five may be expected. A loss of one engine on a four engine configuration may result in a score of 7.5, etc. A *lesser downgrade* may be made if an engine (or engines) becomes so notably marginal in power contribution as to impair flight performance i.e., NOT operating in a synchronized fashion with the remaining engine(s). A lesser downgrade may also apply for an engine or engines quitting very late in the flight, such as on final approach or landing, if the power loss is not a vital part of remaining flight performance.

.2 The ability of the contestant to fly the aircraft with one or more engines malfunctioning (or dead) will not be considered for scoring this MECHANICAL scale operation

.3 After taxi back from flight, the judges should verify ALL engines are still operating. If not, a ½ point deduction is applicable to this mechanical option even if no other anomalies were noted prior to the conclusion of the flight. **NOTE:** Taxi back is also a requirement for Overall Flight Realism with a ½ point consideration. Fast idling engines that inhibit realism during a taxi shall also be downgraded as part of “power management” in “Overall Flight Realism”. Such an idling problem or anomaly to Overall Flight Realism also applies to single engine aircraft.

6.2 Swing or Folding Wings: This option will be judged in two parts, as the aircraft is taxiing away from the judges before take off (up to 5 points), and after the aircraft lands and has begun the taxi back (up to 5 points for a total of 10). The wings do not have to be synchronized in operation (as many full size were not) but should not flop unrealistically as they travel over

center. On swing-wings, both wings should operate together in a synchronized manner, and be extended on the taxi out and retracted on the taxi back.

Scale Operations: Scale operation(s) must be combined with a pilot skill related maneuver as described below. The scale operation of *flaps, slats, and retracts* will be judged a part of the *Overall Flight Realism* score for prototypical options, however they may also be included in the “Slow Speed Dirty Inspection Pass as a maneuver combination (see 8.4).

MANEUVER COMBINATIONS

Section VII Maneuver combinations

All other scale operations that are briefly used or deployed for independent scoring must be presented, or complemented, with a skill related optional flight maneuver. Each maneuver or maneuver combination must be a different recognized selection (non redundant). These optionally selected “maneuver combinations” will frequently be referred to in this Guide for a contestant to define a 10-point scored option. This is further described in Maneuver Scoring Content.

Examples:

- Any ***maneuver combinations*** shall adequately be named and listed by the accompanying maneuver and scale operation feature(s) on the flight sheet for scoring. For example: Cuban Eight *with* Smoke, Rectangle Pattern *with* Parachute Drop, etc., should be listed. The contestant can expand upon these as may be applicable to the full size aircraft operation.

A straight and level *strafing run* is not permitted as a maneuver with or without a scale operation. Options that include a "droppable" **must** be performed in conjunction with some non-redundant form of an applicable flight maneuver other than simply straight flight. For example, this may take the form of a rectangular or triangular pattern maneuver using the leg nearest the judges to execute a bombing run and bomb drop for a typical non-aerobatic loaded bomber. This might then be identified for example as a ***rectangle pattern with bomb drop***. Other unique agile bombing runs may consist of a descending or “reverse Chandelle with bomb drop” on to the target area. Also a sustained bomb run with notable descending angle greater than 30 degrees may be used such as ***glide descent with bomb drop*** or near vertical greater than 70 degree ***dive with bomb drop***. This can be further complemented with applicable high drag aerodynamic scale operational features. Tank-drop maneuvers must also be combined with some action entry or exiting maneuver. For example, these could include ***tank drop with Immelman turn, tank drop with procedure turn, tank drop with split S***, or each reversed in order, etc. A ***torpedo drop with escape*** must be low in approach and release must be immediately followed by a gradual ascending notable turn of 90 degrees or more away from the intended target. This may take the form of a Chandelle if the turn is 180 degrees. Crop dusting (or smoke) must also be simultaneously complemented within the listed maneuver by some form of non-redundant and notably realistic flight skill precision. For “obstacles with crop dusting”, this would include descending abruptly for a low pass near crop level. After a brief period of spray, it must again ascend quickly to clear obstacles. A crop dusting low pass could also be immediately followed with a procedure turn or Chandelle, i.e. ***crop dust with Chandelle***, etc. Parachute drops by a non-aerobatic aircraft could also be complemented by a rectangular pattern, or by deploying at the end of a procedure turn for any aircraft.

7.1 Mechanical and Maneuver combinations Limited to 3 Total: The maximum total number of mechanical and ***maneuver combination*** options permitted in any flight will be 3. However, the same mechanical option or scale operation that supports a maneuver combination option may be used only once for scoring in a flight (see 8.8).

7.2 Maneuver variations based upon type of aircraft. The type of aircraft presented will determine the size, shape, and content of a maneuver. Flight judges will be open for verbal explanations of maneuvers that may vary slightly from those described in this publication. If not the case, a signed Maneuver Declaration Worksheet as described in section 4.10.7 should be shown to the flight judges. The following illustrations show some examples of maneuver variations based on aircraft types.

Note: "Maneuver Combination" is a U.S. Scale Masters exclusive invention over the last decade that addresses the concern of the "flip a switch for 10 points" and the advantages it had previously offered to various aircraft. This had also handicapped many vintage aircraft that had no retracts, flaps, slats, sliding canopy, tail hook, or other such items for corresponding exclusive scale operations on the score sheet. These scale operations also had little regard for true piloting skills. So while these neat mechanical options are still enjoyable to watch, it was very questionable these items represented true piloting skills unless they were further combined with some flight maneuver. Hence the "Maneuver Combination" was implemented to place further emphasis on piloting skills in the U.S. Scale Masters Championship program.

Variations in what to expect based on type of aircraft:

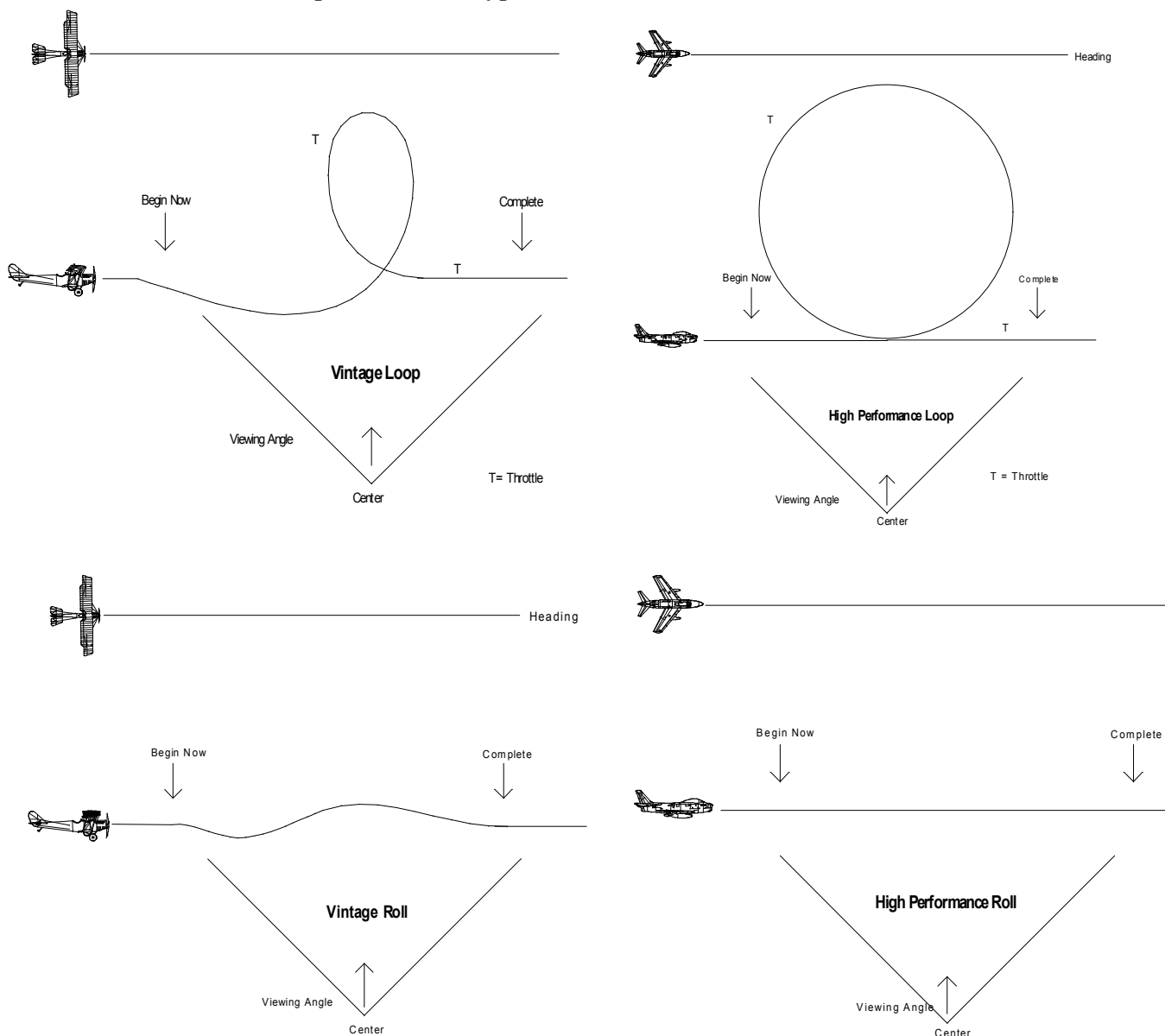

OPTIONAL FLIGHT MANEUVERS

Section VIII Optional Flight Maneuvers

NOTE: The following flight maneuvers or *maneuver combinations* are described for further clarity and definition.

The contestant has five options to select beyond the mandatory maneuvers. The flight routine should be selected to represent a flight mission or maneuver sequence that best displays the flight characteristics of the aircraft modeled. Contestants may change flight options between rounds, but no changes may be made once their flight has begun. For maneuvers that are not documented either within this guide or other approved guides, a blank Maneuver Declaration Sheet is provided in the back of this guide. The CD or AMA Scale Board Member will need to sign off on this prior to your flight. Supporting documentation is welcome.

8.1 Touch-and-Go:

The touch-and-go option requires the aircraft to slow sufficiently after landing to *below flying speed*, before again accelerating for the “GO” prior to take-off. This does *not* require that the tail wheel or skid settle to the ground for “tail draggers”. All other qualities expected of landing and takeoff will prevail including the start of this maneuver at the beginning of the final approach. The maximum score for this maneuver sequence is 20 points, i.e. 10 points for “TOUCH” and 10 points for “GO”. The start of the “GO” maneuver will coincide with the throttle acceleration after previously being slowed. On prototypes so equipped, flaps and retracts would be used on both sides of the maneuver. When coming in, the flaps and gear should be down. When departing, the gear and flaps should be retracted in the same sequential manner as would be expected for a Takeoff or Slow Speed “Dirty” Inspection Pass where flaps are retracted last to avoid stalls. Maneuver should be scored from the time the flaps and gear are deployed and finished when gear and flaps are fully retracted again. Each maneuver must be listed by the contestant on two separate consecutive lines of the score sheet one as “Touch” followed by “Go” in the next maneuver box.

8.2 Traffic Pattern Approach: The traffic pattern maneuver may be elected as an option for any aircraft. It may be performed as a standard rectangular pattern or with other prototypical described Navy methods such as with a semicircular 180-degree pattern replacing the last 90-degree crosswind leg before final approach. The initial part of a traffic pattern entry may also be revised for applicable prototypical tactics to minimize exposure of attack in military aircraft. This may include a low entry approach on the far side of the defined runway and a notably climbing pitch out away from the judges into a 180-degree turn, during which retracts (if applicable) are initiated in extension and continued into the downwind leg. This shall be followed by a rectangle or semicircle entry to final approach. Traffic pattern variations must be briefly described to judges prior to flight. Only one traffic pattern maneuver option variant may be chosen in a flight, unless further choosing the “Sideslip” maneuver on a *separately judged* final approach performance.

- .1 If any one of these Traffic Pattern options is chosen, it will end at the start of the final approach to Landing in alignment to the runway. It can also be optionally placed just prior to Overshoot, Touch and Go, or Spot Landing, but may be used only once per flight. These other optional maneuvers would also start at the beginning of their final approach. The initial decent may also begin in the final crosswind leg (or semicircle) of the Traffic Pattern prior to these other maneuvers.
- .2 If flaps, slats, and (or) retracts are prototypical features of the aircraft, they must be timely deployed for optimum Overall Flight Realism scoring. Retracts shall be deployed in the downwind leg for the standard rectangular traffic pattern. Flaps (and slats) shall be deployed

initially either in the downwind leg or in the final crosswind (or semicircle) and progressively increased thereafter as may be prototypical to the aircraft. This maneuver shall not be classified as a “maneuver combination” to dilute pilot precision, or placement with scale operations. The failure of anticipated prototypical scale operation(s) to timely deploy will be downgraded for lack of “OPTION Precision” and “Continuity” for that portion of Overall Flight Realism score.

8.3 Spot Landing: The optional Spot Landing maneuver is given the same score as Landing **if** the initial wheel touchdown is within a 100-foot diameter circle centered in front of the judges and defined runway. If the runway width prohibits this defined circle, then the judges and contestant must agree that the spot landing area be a rectangle whose width is that of the defined runway and length is 100 feet centered in front of the judges, i.e. 50 feet to the left and right. **If** the aircraft initially touches down inside this defined area, the score for Spot Landing option becomes the *same as* that given for Landing. If the initial touchdown is outside this defined region, the Spot Landing option score becomes zero and the Landing is scored in the same manner it would have been without spot landing considerations. Both judges must agree as to whether or not the aircraft touched down in the defined region. This maneuver may not be listed as a **combination maneuver** with flaps/slats or retracts to dilute pilot precision. All other requirements of the Landing maneuver apply including starting this maneuver at the beginning of the final approach.

- .1 Due to difficulties in judging regions offset from *judges' centerline*, no offset centering of the defined 100-foot region will be permitted, unless approved by the CD. **NOTE:** Contestant Beware: With limited runway length, this maneuver option may not be very practical for certain aircraft when runway facilities are not optimum. In such cases, the C.D. may preclude this option entirely at the event to preserve a high level of overall judging accuracy. Judges Beware: This is the most frequently misjudged maneuver when different scores are given for Landing and Spot landing when the wheels did touch in the 100 diameter circle.

8.4 Slow Speed “Dirty” Inspection Pass (*maneuver combination*):

This maneuver is only allowed for aircraft with flaps as a minimum. Where applicable, other “dirty” features such as retracts must also be deployed. It is considered a “maneuver combination” in scoring content per 4.9. The Precision, Placement & Realism scoring content for this maneuver combination shall be scored relative to judging center with 5 points maximum for the entry portion of the maneuver and 5 points maximum for the initial clean-up portion after judging center. To simplify judging, only 150 feet prior to judging center and 150 feet after judging center shall be scored for the maneuver portion. Since this is scored as a maneuver combination with scale operations (see 4.9.1), the deployment of “dirty” scale operation features may occur prior to this described maneuver judging window distance as well as the final stages of scale operation clean-up extending beyond the judging window distances.

The pilot must demonstrate the ability to fly the aircraft slowly in a "dirty" configuration near stall speed with flaps deployed as a minimum along with any other applicable “dirty features” and, smoothly start to transition the aircraft back into a clean configuration.

- .1 At any time before establishing the heading for the Dirty Inspection Pass, the aircraft should be slowed sufficiently to deploy flaps (and slats where applicable) as a minimum. Also the landing gear shall be deployed in addition to any other feature(s) that are characteristic of the aircraft for its dirty appearance as would be seen for a possible landing configuration (slats or tail hook deployed if full size aircraft had these). The judging of the maneuver begins after establishing the heading at an altitude of 20-40 feet and a 150 foot straight fly by Inspection Pass is

performed where all applicable prototypical features must be in the fully extended position for that distance prior to reaching judging center. At judging center, the pilot begins to increase the throttle setting and then starts to raise the landing gear (where applicable) immediately after passing the judges. Also the flaps are slowly raised as speed is sufficiently increased to avoid stall while maintaining the heading already established. Where applicable, the slats or tail hook are also retracted during this period. For judging purposes, the maneuver portion for scoring is considered complete 150 feet after judging center if proper placement is used despite any extended cleanup for scale operations beyond that point. Since this is a “maneuver combination,” equal emphasis in scoring is given to both the maneuver and the scale operation feature(s) as described in scoring content section (par 4.9). The center of the maneuver is judging center for optimum placement where the power should again be applied for subsequent cleanup. Therefore the Precision, Placement, and Realism shall be scored accordingly for this “maneuver combination.” At the conclusion of the flight, judges may also ask the contestant to demonstrate the deployment of flaps or other features that were not clearly visible during the flight after landing to confirm they were functional.

Restrictions and Requirements:

Aircraft must have flaps as a minimum to perform this maneuver. Additional items such as retracts, retractable tail hook, or other applicable features that are used in a typical landing configuration for the type of aircraft being flown shall also be deployed at the pilots command for achieving optimum slow speed and dirty appearance effects.

Downgrades:

Speed of Dirty Inspection Pass is not significantly slower than other flight maneuvers including mandatory Fly Past. Deviations from heading occur. A 150-foot minimum length dirty inspection configuration is not established prior to judging center where speed is at a minimum. Power is not applied immediately after passing judging center. Abrupt pitch/trim changes occur in the initial stages of cleanup after passing judging center.

8.5 Chandelle: Any aircraft can perform this prototypical optional maneuver.

Described as an exaggerated climbing turn in which the airplane changes direction through 180-degrees emerging at a higher altitude upon exit. The bank angle, speed, and rate of climb depend upon the type of aircraft being flown. For example, a vintage aircraft may begin with a shallow dive to pick up speed, the nose should then pull up and the model begins a steady climbing turn proceeding away from the flight line. A high performance aircraft would enter the maneuver from straight and level and exhibit a higher bank angle and rate of climb. Entry speed should be sufficient to prevent visible slipping or skidding and maintain the same rate of turn throughout the maneuver. The maximum bank angle may be 45 to 60 degrees for non-aerobatic aircraft and up to 90 degrees for fully aerobatic aircraft. The degree of bank angle and rate of climb are constantly changing as the speed continues to decline through the maneuver. When the model has completed the 180-degree turn, the wings are leveled and the maneuver is called complete. It is expected that the model would be flying at a reduced speed compared to entry.

8.6 Procedure Turn: Any aircraft may do this individual maneuver however; it shall not include the straight-flight entry or exit as additional scored options. The Procedure Turn is positioned in the Scale Masters Program where the initial 90 degree turn away from the runway begins *before* reaching judging center, and the remaining 270 degree turn optimally starts at judging center to

the left or right. **NOTE:** This is identical in desired position as the start of the mandatory figure eight for optimum judging view.

8.7 Roll Variations: A variety of roll styles or configurations may be chosen as options, which are not considered redundant in skill if carefully performed with the noted differences. These include axial rolls, barrel rolls, inside or outside snap rolls, etc. **AMA/FAI Competition Regulations contain good descriptions and graphical representations of many roll maneuvers that can be used.** Also swing-wing aircraft may perform two different axial style rolls if they are aerodynamically different when the swept wing mode becomes a “taileron roll” and the extended wing mode remains a conventional *aileron roll*. For such examples, swing-wings effectively provide greater aerodynamic flight options similar to full size. If “taileron roll” is selected in this manner, it may optionally be performed as a **maneuver combination** to share in pilot Precision with the variable swept-wing (scale operation) feature. However this **maneuver combination** option can be elected only if the variable swing-wing feature has not become redundant to the mechanical option of swing-wings (also see 9.4).

8.8 360 Degree Descending Circle at constant low throttle setting

.1 Commencing from straight and level flight, the model aircraft performs a gentle 360 degree descending circle in a direction away from the judges at a constant low throttle setting. The maneuver terminates at a height between 10 and 20 feet resuming straight and level flight on the same path.

Errors: rate of descent not constant. Descent too steep. Throttle not constant or low enough. Circle misshapen. No significant loss of height. Descent not to a level of 10 or 20 feet. Circle not centered on judge’s position. Entry and exit paths not parallel with judges line. Too far away or too close.

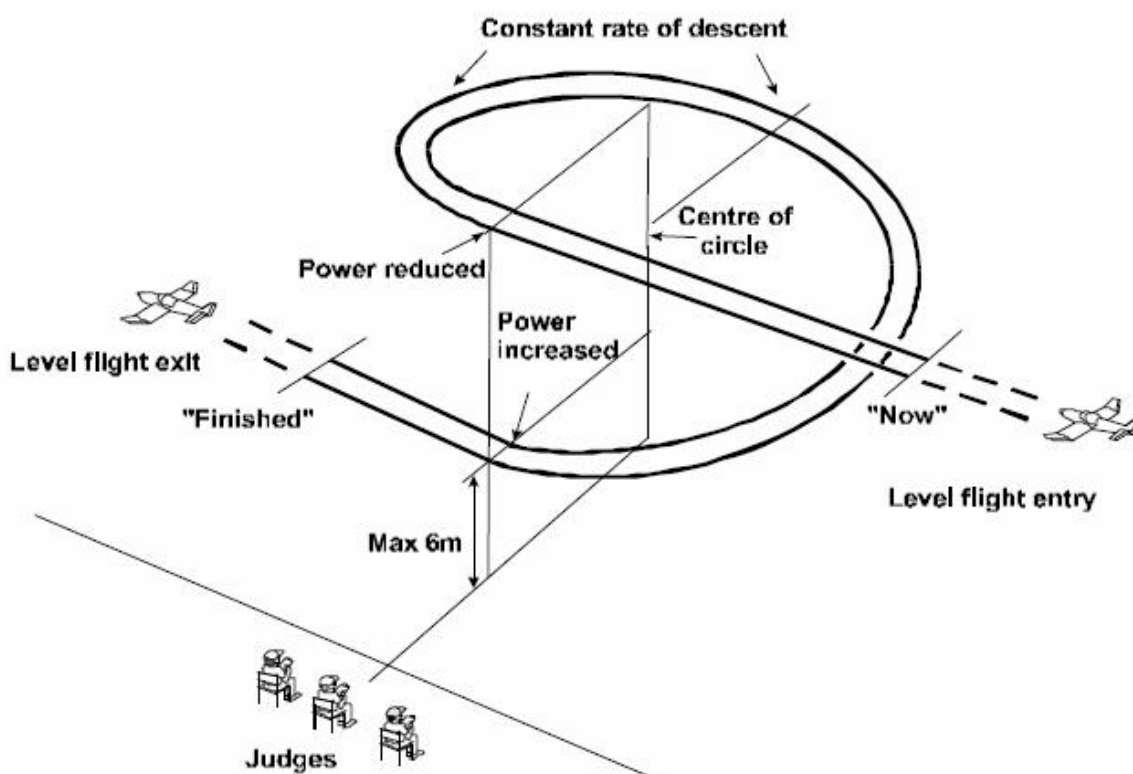

8.9 Lazy Eight

.1 The model aircraft approaches in straight and level flight on a line parallel with the judges' line. After passing the judges position, a smooth climbing turn is started away from the judges. At the apex of the turn, the bank should be at least 60 degrees. The nose of the model aircraft then lowers and the bank comes off at the same rate as it went on. The turn is continued beyond 180 degrees to cross in front of the judges with wings level before intercepting and turning on to the reciprocal of the original approach track. This completes half of the figure, which is then repeated in the opposite direction to give the full symmetrical maneuver about the judges' position. Intercepting the original approach track parallel with the judges' line completes the maneuver. A low powered aircraft would be expected to execute a shallow dive at full throttle in order to pick up speed before starting the maneuver. This maneuver is essentially two wingovers in opposite directions and should be capable of being flown by most aircraft.

Errors: Entry and exit paths not parallel with judges' line. Insufficient climb achieved. Insufficient bank achieved. Climb and descent angles not equal throughout maneuver. Arcs misshapen. Maneuver not symmetrical about judges' position. Start and finish positions not as indicated. Overall size of maneuver not realistic for prototype. Model aircraft flight path not smooth and steady. Too far away/too close/too high/too low.

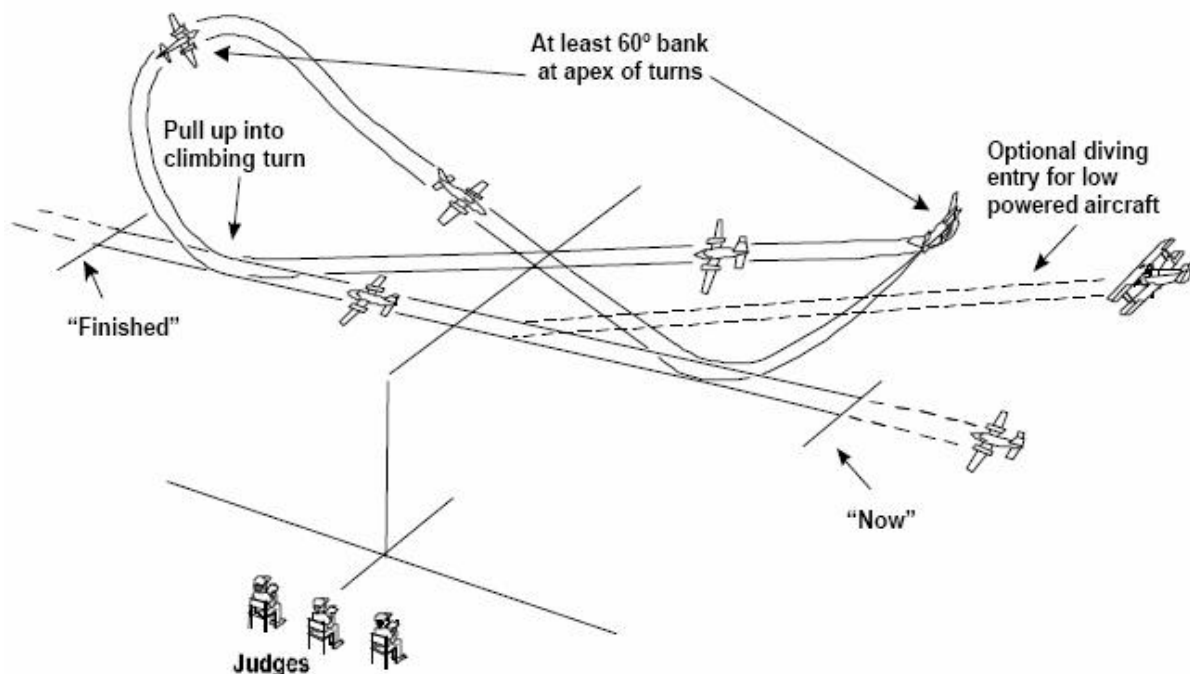

Note: Descriptions and diagrams courtesy of FAI Sporting Code SC4.VolF4.06
<http://www.fai.org/aeromodelling/documents/sc4>

8.10 Derry Turn

This maneuver was named after one of the greatest test & display pilots, John Derry. He was tragically killed in the DH110 at Farnborough in 1952.

.1 The model approaches at a high speed in straight and level flight on a parallel line with the judges' line. The model then makes a steep bank (in excess of 60 degrees) one-quarter-circle turn in a direction away from the judges without losing height. When centered in front of the judges, the model makes a half roll in the same rolling direction as the entry, again directly followed by a steep one-quarter-circle turn in the opposite direction, and then flies off straight and level on a line parallel with that of the entry maneuver.

Errors: Entry not parallel with judges' line. Maneuver not centered in front of judges. The rolling maneuver in front of judges not axial on a line directly away from judges. The roll in center is not in the same roll direction as the entry to the maneuver. Any hesitation between the end of the first quarter turn, the roll and/or the start of the second turn. Exit not parallel with entry. Significant height difference during maneuver. The maneuver misshapen (as seen as part of a figure eight). Maneuver is too low or too high to be easily judged.

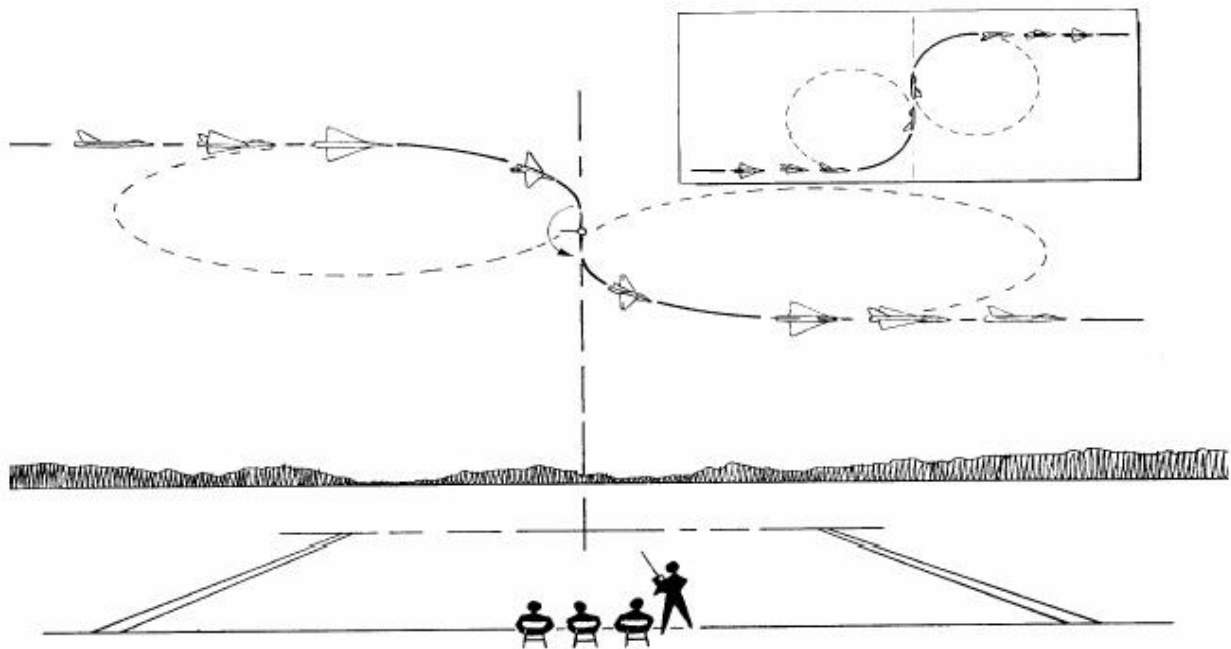

8.11 Other Non-redundant Flight Options: Maneuvers or *maneuver combinations* may not be used where they have been previously used in another maneuver or *maneuver combination*.

.1 Each flight option must be separately performed in an independent manner recognizable for judging in the sequence listed on the score sheet. Use of nearly identical or redundant flight options or scale operations will be scored zero for such maneuver or *maneuver combination* selections. An example of a redundant or nearly identical flight options or maneuvers would be listing a roll, then a military roll, and then a slow roll that might all be performed virtually the same but differ only by name. If different rolls are used that are not considered redundant, they must be sufficiently different both in description and in actual performance for realism to the satisfaction of the judges.

MISCELLANEOUS EVENT LOGISTICS

Section IX Miscellaneous Event Logistics

9.1 Time Limits and “Official” Delays: Time limit for each flight will start from the moment the contestant begins his/her preflight discussion with the judges, and ends at the conclusion of the flight after taxi back (or carry back) to the judges. During the preflight discussion, the contestant can also present documentation he/she believes may be appropriate to explain or defend any unusual flight, mechanical, or scale operational feature(s) of the aircraft. However, this should be kept brief since the clock is running. The CD will designate actual time limit allowed as dictated by various logistical factors of the event at the pilots meeting. This typically is 15 minutes for most events. Once started, such time will be extended only for officially recognized delays (such as full-scale traffic). Also an additional one half minute (30 seconds) will be added for each “multi-engine” beyond the first engine.

- 1.1. If any maneuver is delayed or started and aborted due to an immediate and obvious traffic-safety problem, the contestant will be granted a restart of that maneuver. In such recognized cases, the clock will be extended accordingly. An abort shall not have been deemed necessary for later restart if the maneuver was only *questionably interrupted as an afterthought*, and instinctively continued and completed by the pilot in such a manner that it could be scored in a complete and fair manner by the flight judges. The decision by the witnessing flight judges will be final on such infrequent and unpredictable events!
- 1.2. The clock will also be extended for prevailing ground traffic contest related delays or safety requests to hold in taxi or takeoff without penalty to maneuver or continuity. If “official delays” result in “engine loading” and subsequent engine restart, the clock will also be extended if done in a timely manner without further technical problem(s) and delay. Engine restarts caused by official delays will be put back on the clock after restart or one minute of added time (whichever is shorter).
- 1.3. If any unusual combination of these unpredictable events results in a “formally extended time clock” as to make it unlikely to safely complete a flight, the contestant will be permitted an out of sequence emergency landing for refueling or, in the case of electric powered aircraft, battery replacement. The CD shall be consulted immediately upon landing by the flight judges as to the status and unusual circumstances leading up to this extended flight and emergency refueling. Only those portions of the flight yet to be completed in sequence (including landing) will be permitted immediately or later in that same flight round. The CD for suitable logistical timing within the event activities will further decide this when refueling is completed.

9.2 Transmitter Rule: Touching of the transmitter by anyone other than the contestant to make control or trim adjustment during the scored flight interval (from taxi out to taxi back), will disqualify the entire flight. This shall *also* include such violations during “trim” passes. An engine restart during taxi out or prior to becoming airborne will briefly permit handling the transmitter by another person for restart. However, see “Engine Restarts” for other applicable penalties for such restarts.

9.3 Loudly Announce Each Maneuver Entry: The contestant or caller is expected to loudly announce each maneuver and its beginning to assure the judges are prepared for the specific scored item(s) to follow. Judges should not conclude the “judging period window” until a satisfactory clean exit is recognized, in spite of the contestant abruptly calling... “Maneuver complete!” Most maneuvers are entered and exited in straight and level flight. Therefore the Inverted Flight maneuver must include the half roll entry and exit. Also the combined maneuvers of tank drop entry or exit with other *action maneuvers* must also be considered.

NOTE: The judges should also be alert for realism features *throughout the flight* as described in Overall Flight Realism.

9.4 Ground Option Limitations: Flight options listed for scoring may not include any maneuver or maneuver combination done entirely on the ground. This ground restriction does not apply to Takeoff and Landing maneuvers that are considered important transitional maneuvers from ground to air or air to ground. The only exception to this ground option limitation is the demonstration of folding or swing-wings as a mechanical option done entirely on the ground (see 6.2). As an alternative, the contestant may instead use swing-wings for scoring in a flight maneuver combination (see 8.7) rather than a scored mechanical option on the ground. However the contestant cannot do both options (see 8.8 concerning nonredundant options).

9.5 Engine Restarts: Engine restarts NOT caused by contest related or “official” delays that occur after departing the immediate judging area and prior to becoming airborne will have various deductions in score depending on when it occurs: A minimal 0.5 point deduction penalty will apply on the *informal* taxi out (or back) in the CONTINUITY portion of Overall Flight Realism (whether it is taxied or carried). A zero score also applies during the roll sequence in a formal listed “Takeoff” (10-point loss) prior to becoming airborne. **If the model becomes airborne with flying speed and then immediately lands with engine failure, it is an official flight and may not be restarted.** Engine restarts will remain on the clock and contestant will immediately be informed and reminded.

9.6 Skipped Maneuvers: If any listed maneuver(s) are skipped from the order shown by the contestant on the score sheet, those skipped may not be retrieved once a subsequent maneuver has been entered or performed. If the aircraft becomes airborne with flying speed but is also forced to land immediately thereafter, it is an official flight and all other maneuvers have effectively been skipped without retrieval (regardless of aircraft and options).

9.7 Takeoff and Landing Aborts: In the interest of safety, a takeoff or landing may be aborted and restarted with 7 points (or 70% for each subsequent retry) rather than be given an automatic zero. The contestant will still be on the clock for these additional attempts. Example scoring: After the first abort, the *maximum* score for the first *retry* is 7 points, 2nd retry is 5 points (70% of 7), 3rd retry is 3.5 points, etc. The Scale Masters program does not want anyone to jeopardize safety of the judging line because the pilot felt compelled to continue a bad takeoff roll or landing simply to avoid an automatic zero score.

9.8 Flight Line Sequence Changes or “Mulligans”: These are any contestant requested changes to the approved flight line order, or request to go to the end of a flight line after the contestant is on the clock.

.1 The CD will announce in the pilots meeting which option is to be used as dictated by the number of contestants present and the logistical schedule of the meet. There are three options available:

A). The only flight order changes or second opportunities permitted are those for damage repair, technical anomalies, or transportation damage. All such anomalies used to justify changing the flight order must be declared by the contestant and be approved by the CD **before** the contestant has been put on the clock. Once the clock is started, the contestant cannot request a second “shot” opportunity (Mulligan) to go to the end of the line. When a “Mulligan” has been granted and the contestant is still not ready to fly at the end of the flight round, the flight will be forfeited.

B). No exceptions to listed flight order or “Mulligans” will be granted whatsoever due to the logistics of the event. ***This choice is primarily used at the Masters Championship Event.***

C). Allow one Mulligan on the first round only.

9.9 Maneuver change: Selected maneuver options for any flight may be changed by the contestant for the next round flown. Such changes on the flight score sheets are the responsibility of the contestant prior to each flight. If dropables are used in static, they must be used in the first flight. They may be deleted in listing as a complementing option thereafter if desired.

9.10 Flight Realism and Score Sheet Review: After the flight has concluded, the flight judges shall confer to review the numerous Overall Flight Realism qualities as described in this Guide. Identical flight realism scoring is not required. Individual judgment scores will still be of value for statistical averaging similar to others. Any zero scores given for any maneuver shall be mutually agreed upon by both flight judges and both will give identical scores of zero.

1. If the contestant had declared the aircraft to be Non-Aerobatic, that should be so noted on the check box of the flight score sheet for future reference. Before the score sheets are picked up, each individual judge must put his/her initial in the upper column heading for the flight round just concluded *after verifying that all line item scores have been included*. The flight score sheet provides a space for each numerical digit (up to three spaces). Scores should be to the nearest ½ point (for example 8.5). With the exception of the perfect score of 10.0 only two of the three spaces provided are required.

9.11 Static Judging. If more than 20 contestants are expected, the Dual Simultaneous Judging method is suggested where two additional tables are set up (See Fig. 10 below). While one aircraft is being judged, the other is being set up and the documentation is prepared on the table behind the judges. When the judges are finished with one aircraft, they turn around, pick up the documentation and immediately begin judging the next aircraft. This system is capable of 8 aircraft per hour, which still gives the equivalent of 22.5 judging minutes per plane (7.5 minutes x 3 judges).

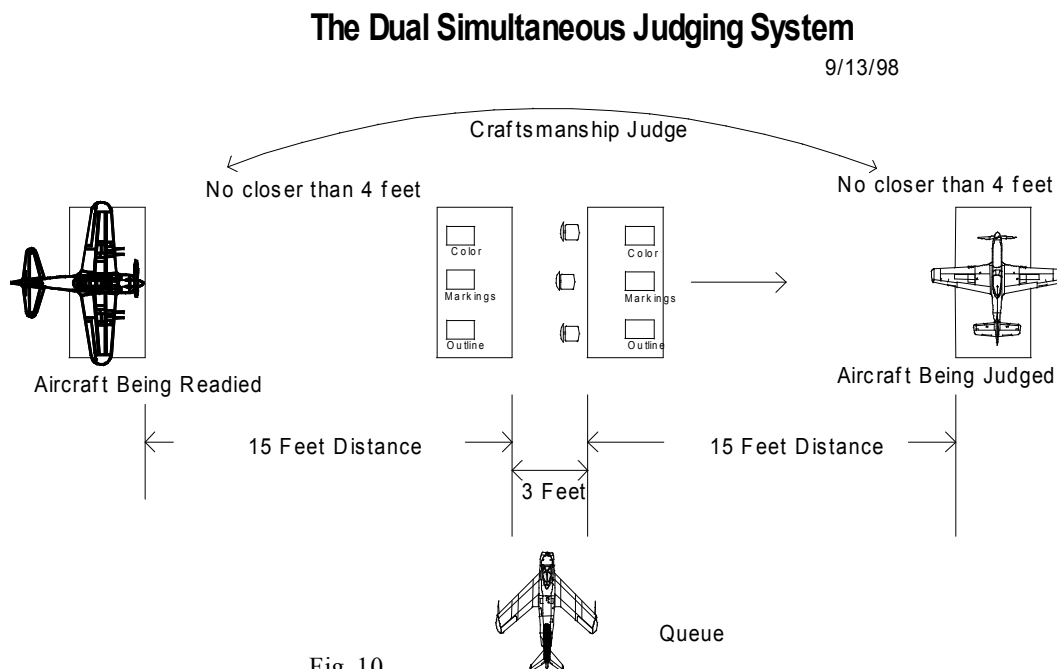

Fig. 10

Note: This is a Scale Masters exclusive invention that provides efficient and effective judging for large quantities of aircraft such as found at the Masters Championships. The method addresses the lost time judges experienced in the past from waiting for the model to be set up and removed after judging. In many cases, lost time exceeded the actual time spent judging in the serial judging fashion used in the past. Another interesting point is the accrued judging time in minutes is actually greater than the judging time using the serial process. If there are 4 static judges (Outline, Color, Markings, Craftsmanship) and the process takes 8 minutes the time the model is being judged is 32 minutes. If there were 3 static judges the time would be 24 minutes. In the past, were there were 3 tables (Outline, Color & Markings, Craftsmanship) the modeler had to shuffle from table to table. Time at each table averaged 6 minutes but there were 3 minutes of setup and take down. To the modeler the process took over 27 minutes to get through all 3 stations, appearing that static judging took that long. When compared with the efficiency of the Dual Simultaneous Method, the modeler felt that the time was not enough (from what they were used to) and raised questions about the quality of judging. In reality, the amount of time that the model is being judged is greater than before.

9.12 Pilots Meeting Checklist example

The CD should go over items such as the following prior to the first flight.

- Welcome! We are glad you are here!
- Flight Line etiquette - be completely ready when it is your turn
- Smoking policy
- Alcohol policy
- Safety checks on aircraft complete
- All Transmitters must be turned in to the impound
- Runway layout and orientation
- Deadline location
- Judges Center Line
- Maneuvering Line
- If Mulligans are allowed and when
- If it will be allowed to supplement **Takeoff or Landings** with another maneuver in adverse weather conditions.
- Takeoff direction will be mandated by the Air Boss (introduce)
- Fuel critical aircraft to be given priority when giving landing clearance
- Recovering aircraft (landing) will take priority over launching (takeoffs)
- Emergency Medical / Fire procedures: who to contact, location of nearest hospital
- Open for Questions

Remember we are here to **Have Fun!**

U.S. Scale Masters



Judges Certification

INTRODUCTION

Section X JUDGES CERTIFICATION

Thank you for your interest and participation in the Masters Program. Without the judge, the program would not function. Accurate and consistent judging is so important and may seem complex and hard to learn at first, however, the process outlined in this guide will show you the methods needed in order to be successful and to share in this rewarding part of scale modeling. A Judge gets the best seat at the field!

The main objective at any contest is to determine who the best is. From the Olympics to the NFL the objective is the same. A process or method is needed in order to determine the best of the best. Each organization sets up criteria and a process that is fair and consistent so each contestant is judged against the same set of rules. The founders of the Masters Program established the criteria and the process in 1978 and over the years refined it to keep up with new technology. You will be introduced to a few new terms and thought processes that help segment the tasks into bite sized chunks. The fundamental question throughout the process is "Does It Match?" which helps remind us that we are only there to compare a model with documentation and provide a reasonable and fair score for each element.

This guide is for contestants as well. Many times a contestant becomes discouraged or disappointed with his/her score only because they did not know what to prepare for.

Most people are competitive in nature and enjoy the challenge to become the winner. Not everyone can win first place but it can sure be fun trying. Be aware that there are some that really get wrapped up in the Vince Lombardi style of "Winning Is Everything", such that anything less than first place is awful and they go about disrupting the contest, taking away the enjoyment of the rest of the contestants. This is why our mission statement specifically calls out this keyword:

SPORTSMANSHIP

If we can't be good sports about it and have fun, why bother? This is a past-time, recreational sport for most all of the people involved. I certainly don't get paid for any of this so let's have some fun! I wish you the best of luck and may all your projects fly great!

See you on the Flight Line!

Bill

Bill Hart
National Chairman

JUDGING FUNDAMENTALS

The Judging process to someone untrained can seem complicated. It is easy to fall back to ones own standards or background knowledge and fall into the trap of "Do I Like This or Not?" Or coming up with a gut feel score, "That feels like a 7.5 or so". This method is dangerous and is guaranteed to fan the flames of emotion with any contestant. The trained Judge will set his/her background knowledge aside and only compare the model with the documentation provided. Arriving at a score is simply subtracting the downgrades you find from 10. Each element starts at 10 and is downgraded as mismatches are found. A minor (m) mismatch is 1/4 point and a Major (M) mismatch is a full point. If this sounds too easy, relax - it actually is IF you follow the process.

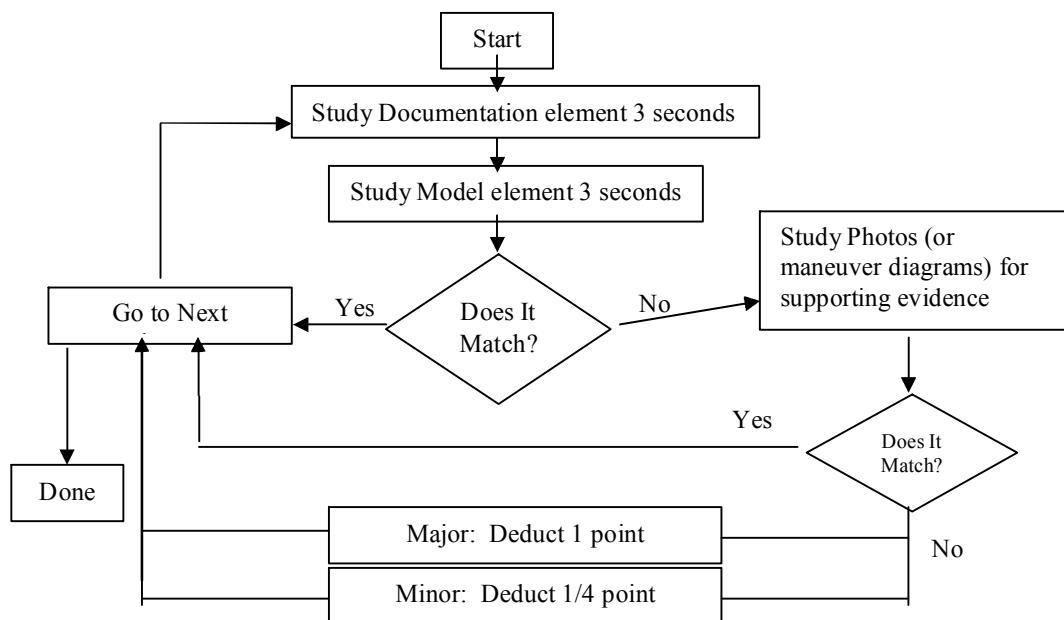

There will be times when there is no documentation provided. No score can then be given for that element. This is the subjective part and every effort should be made to follow a set of standards available to everyone so that the default is the same for the judge and the contestant.

Training is the key to judging success and the U.S. Scale Masters is committed to develop and train to these standards. There is still much work to be done and your input is valued. Feel free to contact USSMA-HQ with any suggestions or ideas that could help with this effort.

The Outline judge will study the documentation item starting at the tip of the rudder then look up at the model. Does it match? If yes, proceed to the next element in a clockwise rotation. If not, look at the photos provided to see if the item shows up in the pictures as photos take precedence over 3-view drawings. If it matches, go to the next item. If the judge cannot find a photo that clearly shows the mismatch the judge must downgrade for that particular item and go to the next item.

U.S. Scale Masters Judges Certification Guide

Prerequisites

- Read and understand the USSMA Competition Guide
- Have 20-20 eyesight (correctable)
- Color Judge must pass Color Blind exam given at local DMV or health clinics or, on line at: <http://waynesword.palomar.edu/colorbl1.htm>
- Pass the corresponding Certification Exam with at least 90% score
- Watch the USSMA Judges Video tape when available (still in process)

Certification Process

1. Study the information contained within this guide. If your eyesight is good (and if Color Judge, pass the colorblind chart available from <http://waynesword.palomar.edu/colorb11.htm> proceed with filling out the on-line application located at USSMA website and take the exam, which is open book. The honor system is used throughout the program.
2. Your exam will be graded and the results will be put in the mail within 1 week. If your score is 90% or better, a letter will be sent to the CD of the regional qualifier nearest you (or the qualifier of your choice) indicating your status.
3. The CD may contact you and schedule the judges' "calibration" session to be held sometime before the qualifier start date. During the session, you will be filling out a flight sheet along with the others and your score will be compared to a reference score determined by the CD. If your scores after the first flight are within 1 point of the reference score (for each maneuver) the CD will sign your score sheet. A copy of this is then sent to HQ for the file. You are then qualified to judge at the qualifier. The CD will ensure you are assigned to another Certified Judge for judging the contest.
4. After the contest, the CD will sign off your application as training complete and a copy is sent to HQ. You will receive a beautiful Scale Masters Certified Judge badge with your name engraved in gold, and the honor bestowed upon those few that are selected.

Static Judging Criteria

The following sections outline the criteria to objectively static judge a model. Develop your system and use this for every model. Judges who follow the judging process arrive at a consistent and accurate score each time.

10.1 Criteria for Accuracy of Outline

As an example of outline criteria, if the vertical stabilizer shape at the tip on the model does not match the 3-views, photo documentation (if supplied) will be reviewed for evidence supporting the model. Since photographs of the actual aircraft being modeled take precedence over 3-views they should be used as the final determination as to whether the vertical stabilizer matches or not. If there is no photo that clearly shows this view, downgrade ½ point if the size/location discrepancy is minor and a full point if major. A minor deduction (1/4 point) is typically where the mismatch is 5% in relative size of the linear dimension relation and for angular relation 2 degrees. Similarly a moderate deduction (1/2 point) is typically where the mismatch is 10% or 5 degrees. Major deductions of 1 point are for mismatches greater than 10% and 5 degrees. No deductions will occur for errors less than 5% or 2 degrees. To determine percentage, consider the following diagrams:

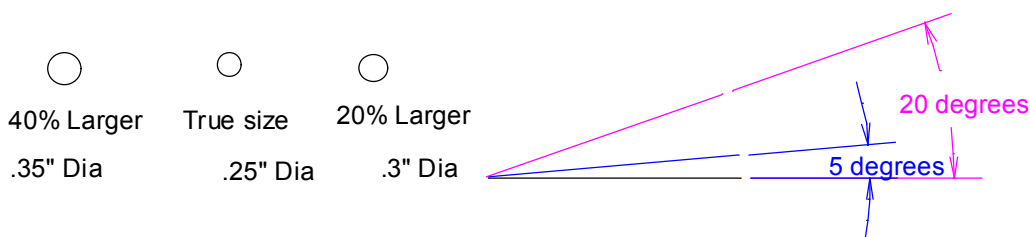

10.2 Criteria for Finish, Color, and Markings

A minor deduction (1/4 point) is typically given where a mismatch is noted but is minor. Moderate or major deductions (1/2 to 1 points) will be typical where the mismatch is readily apparent.

1. **Finish:** This is to include the sheen or reflective properties of the finish, weathering details, and the application of materials e.g.; many WWI aircraft were painted with a brush and brush marks were easily seen even from a distance. If the documentation shows brush marks in certain areas, the model should also show this artifact. The Finish judge should consult with the Craftsmanship judge to ensure an item is not double downgraded, once by the Finish judge and once by the Craftsmanship judge.
2. **Color:** It is the contestant's responsibility to authenticate the model colors by providing documentation such as color photos, published artist conceptions, paint chips, color reference guides, or factory paint samples. Color and hue of the model need to be checked against the color reference provided in the documentation packet. The "sheen" or reflective properties may also be verified from these same samples, but will only be used for scoring the Finish qualities as previously described. Black, Flat Black, or natural aluminum do not need paint reference samples.

3. **Markings:** This inspection verifies size and placement of markings to match the documentation. Ideally, the documentation would show the placement of all markings. However, if no documentation is available, a typical view showing that squadron's markings from references other than the aircraft modeled may be used to depict typical marking locations (these items need to be noted as TYPICAL MARKINGS for the judge in the documentation packet).

10.3 Criteria for Craftsmanship are as follows:









1. Inspect parting-line area of control surfaces for visibly unrealistic hinging, uneven fit, or gap on both top and bottom.
2. Inspect for inadequately disguised model-related disassembly sections in wings, cowls, empennage, etc., checking for poor fit or unrealistic appearance including large screw heads in conspicuous areas or “model” type exposed control horns that are not scale.
3. Inspect for correct prototypical choice in hidden or exposed control arms or linkages to elevator(s), rudder(s), ailerons, etc., as depicted in the documentation.
4. Inspect quality of simulated metal-skin features for applicable three-dimensional panel lines, scale rivets (raised or flush), or fastener detailing. Verify approximate scale uniformity in size, spacing and correct three-dimensional effects of these features top and bottom.
5. Inspect for applicable fabric-covered surface sections in cosmetic appearance. Also verify “taping” appearance when applicable for fabric-covered surfaces.
6. Inspect for quality in rigging or connector detail on externally braced aircraft such as biplanes.
7. Inspect for quality in detailing any applicable small protruding pitot tubes, antennas, air scoops, hooks, pods, etc.
8. Inspect for quality in visible dummy engine detail including exhaust and stains where applicable.
9. Inspect for any unrealistic model damage anomalies regarding shrinkage, scuffing, scraping, peeling, tears, or gouges. Simulated wear such as realistic metal dents or exposed bare metal in painted regions for high-wear areas common to aircraft may enhance the model rather than be cause for downgrade.
10. Inspect for applicable window or canopy EXTERIOR detail quality insofar as framework and their resolution from the transparent window regions. Also verify overall exterior fit to airframe or adjoining multiple canopy sections when applicable. A functional sliding canopy is not required, but the described cosmetic static appearance is.
11. Inspect for realistic quality detail features of the landing gear, which are generally additional to the basic machined, stamped, or wire drawn strut components. A downgrade is applicable only if the gear struts are void of realistic detail qualities independent of materials used. Typical off the shelf landing gear do not include items such as brake lines, tie down hooks, fill ports, scissors, drag links, or wheel covers (front and back) that match full size aircraft. These are the “extras” that a modeler can detail out to affect the craftsmanship score in this area.
12. Inspect for applicable wing tip and taillight (etc.) feature qualities for their realistic detailed appearance. Functional illumination is not a requirement for optimum score.
13. Inspect for unrealistic surface defects like wood grain, sanding marks, fillet defects, cracks, voids, pinholes, etc.

Flight Judging Instructions and Automatic Downgrades

Most of the criteria have already been called out in the maneuver descriptions. There are a few items to ensure before and during the flight:

1. Ensure the flight sheet has been completely filled out by the contestant when they hand this to you. Common items that are missing are the checkbox in Aerobatic or Non-Aerobatic aircraft type, their name and registration number in each flight round box.
2. Check the flight sheet for any comments by the CD about items attached to the aircraft during static judging such as wing tanks, bombs, torpedoes, etc. These items if presented at static should be on the aircraft for flight.
3. Next, make sure there is a pilot visible in the aircraft if there should be one visible.
4. List of **Automatic Downgrades** are as follows:
 - a). No Retracts. If the model does not have retractable gear when the full size did, then deduct 4 points from the Overall Flight Realism score.
 - b). No Flaps. If the model does not have or the pilot does not use flaps during the flight where applicable, deduct 2 points from the Overall Flight Realism score.
 - d) No Pilot Figure. A pilot figure must be visible during flight (if the full size was visible) or the score will be downgraded by 2 points for Overall Flight Realism.
 - e). Flying through the sun. If the pilot flies his aircraft directly into the sun during the scoring portion of a maneuver, the flight judge downgrades that maneuver by 2.5 points (zero score for placement).
5. Remember that the contestant starts each maneuver with 10 points. Each maneuver is scored against the three elements; Precision, Placement, and Realism with downgrades according to the severity of the mismatch in each element (see Section IV on page 13).
6. Be fair and be consistent. With each score, ask yourself is this fair? Is this consistent with other scores I have given for similar aircraft/maneuvers? Establish your own system of keeping track of the downgrades for each of the elements during the maneuver.
7. A Feedback Symbol key is provided on the bottom of the flight sheet and is used to point out the major source of downgrade for each maneuver. The flight judge should write in the box just to the right of the score box one (or more) symbols as feedback for the pilot so they can improve their score on the next flight.

Examples of Feedback Symbols:

+ Bank Angle Too Steep		Entry Altitude not equal to Exit Altitude
- Bank Angle Too Shallow		
 Too High		Off Center
 Too Low		Jerky, not smooth
		Symmetry off
		Heading off

- Note1: There may be other symbols used particular to a judge. It is okay to ask them what it means for clarification.
 Note2: Judges are encouraged to share their symbols with USSMA to include in the next revision of the Guide.
 Note3: There is no symbol for "scale speed", instead the optimum speed required is determined by maneuver realism and speed-sensitive "realistic bank angles in turns" as described within the Definitions section of this Guide.

Definitions

Builder of the Model is the individual who constructed the airframe from raw materials or from prefabricated components as found in a kit such as fiberglass formed skin components, foam cores, canopy or plastic molded exterior details, wheels, etc. The same individual, with material of his or her choosing, shall also perform all final assembly and finishing (painting) of the model. Any other commercially advertised products may also be used without penalty to the modeler at the various stages of construction. Hardware independent of airframe (visible or not) requiring machining or welding to assure reliability, safety or the required operations of the scale model aircraft such as radio, engine accessories and, undercarriage gear commercially acquired or designed by the modeler for optimum outline accuracy, may be commissioned independently when in the judgment of the modeler commercially available items are not adequate. No other airframe construction may be commissioned in this manner.

Optimum Speed for overall flight realism is defined as that optimum speed which provides maneuver realism for realistic flight attitude appearance including bank angles in turns, realistic g-loading appearance and with appropriate maneuver size. For example, the model should not be flown excessively fast where it may demonstrate unrealistic high bank angle attitudes and high g-loads. Also, the model should not be flown too slowly where unrealistic shallow bank angles or flat turns do not simulate the full-scale aircraft. For further information on this subject, you can refer to the article “Maneuver Realism Speed” at: http://www.scaleaero.com/maneuver_realism_speed.htm

CD: Contest Director, as certified by the AMA. The CD is responsible for overall safety, organizing and running the contest.

Air Boss: The person in charge of the active flight line. Ensures safety of aircraft, pilots, crew, and spectators. Stages the aircraft up next on each flight line. Gives pilot's clearance to runway accesses.

Non Aerobatic means the aircraft was not capable of inverted flight or extreme attitudes that would endanger the aircraft and/or pilot. Similar to FAA descriptions, a non-aerobatic aircraft is not rated to exceed 60-degree bank angle or 30-degree pitch angle.

Judges' Centerline is an imaginary line straight out from the judges' position, perpendicular to the runway.

Maneuvering line is an imaginary line parallel to the runway, 10 to 50 feet beyond the far side of the active runway. The 10-foot line would be for slower flying aircraft and the 50-foot line would be for faster models like high-speed jets.

Judges' Deadline is an imaginary line parallel to the runway even with the judges' position. It extends out to infinity both left and right directions.

Viewing Angle is defined as a 90-degree field of view for the judges equally spaced from the judges' centerline e.g., 45-degrees to the left and 45-degrees to the right of center.

Reference Documents

Federal Standard 595 Color Chip Book is used for color *reference*, available from the General Services Administration (GSA)¹.

AMA Competition Regulations available for \$2.50 from Academy of Model Aeronautics, 5151 East Memorial Drive, Muncie, Indiana, 47302

FEDERATION AERONAUTIQUE INTERNATIONALE (FAI) Sporting Code. Avenue Mon Repos 24, 1005 LAUSANNE, Switzerland. As found on the World Wide Web at: <http://www.fai.org/aeromodelling/documents/sc4>

¹ General Services Administration, Rm. 6654, Attn: Specifications Section (3FBP-W), 7th and D Streets SW, Washington, DC 20407

Builder of the Model Declaration

All Expert and Team Builder contestants competing in Scale Masters events shall agree to the following “Scale Builder-Flier Rule” and ensure the Contest Director that they understand the requirements of this rule before entering his or her model in competition at Regional Qualifiers or the Masters Championships events.

Scale Builder-Flier Rule: The builder and flier of a scale model shall be one and the same person except in Team Scale, Advanced, Open, or Fun Scale. There shall be no team entries in Expert, Advanced, or Open categories. The Contest Director will make every reasonable effort to assure himself/herself that each Expert contestant or Team Scale builder contestant has constructed the model he/she uses in competition.

“Constructed” shall mean the action required to complete a model airframe with no more prefabrication than is contained in the commercially available kit chosen to model.

Kits containing a large amount of prefabrication are permissible as long as the builder completes the final assembly and finishing of the parts, covering, final painting and applying the markings. This includes Almost-Ready to Cover (ARC) models if the model still requires these actions by the builder. If not, it must compete in Advanced, Open, or Fun Scale. If the model is an Almost-Ready to Fly (ARF) requiring very little building, covering or painting, and/or applying markings, then it is excluded from the Championships Event except in Advanced Class. Reworking such models, no matter how extensive the effort, does not constitute 'Building the Model'. The Builder of the Model shall have satisfied the requirements of the U.S. Scale Masters Championships if the individual has constructed the airframe from raw materials or from prefabricated components as found in the kit such as fiberglass formed skin components, foam cores, canopy or plastic molded exterior details, wheels, etc.

The same individual, with material of his or her choosing, shall also perform all final assembly and finishing (painting, markings) of the model. Any other commercially advertised products may also be used without penalty to the modeler at the various stages of construction.

Hardware independent of the basic airframe (visible or not) requiring machining or welding to assure reliability, safety or the required operations of the scale model aircraft such as engine accessories and undercarriage components, may be commercially acquired or designed by the modeler for optimum outline accuracy and commissioned independently when in the judgment of the modeler commercially available items are not adequate. No other airframe construction may be commissioned in this manner.

I have read the above Scale Builder-Flier rule and attest to the fact that I am the builder of the model aircraft entered.

Scale Model Entered

Contestant Signature

Date

U.S. Scale Masters Program
Official Protest Form

Purpose: To provide a forum for a contestant to log a complaint, request a review of a score, or a note a situation requiring investigation.

Process: Fill out the form and describe in detail the situation to review. Sign and date at the bottom. Give to the Contest Director and allow 1 hour to process. The CD will respond to you within the hour and may request additional information or present a solution. If you are not satisfied with the results, a copy of this can be sent to Headquarters for further investigation.

Name: _____ Aircraft: _____ Contest: _____

Description of Situation: _____

Requested Action: _____

Signature: _____ Date: _____ Time: _____

Contest Directors' Action/Solution:

NOTE to CD: Please report all Official Protests to HQ

CD Signature: _____ Date: _____ Time: _____

Sent to USSMA Headquarters on: _____

U.S. Scale Masters Association
Bill Hart, National Chairman (714) 894-2747
9151 Larkspur Dr
Westminster, CA 92683-7324
billhartwestmin@yahoo.com

STATIC JUDGING



Scale Masters Championships

Reg# _____

NAME: _____

AIRCRAFT: _____ Class: _____

Mark in 1/4 point increments

NOTES TO JUDGES

- This form is intended to accomplish the following aims:
- Promote scoring consistency among a wide assortment of replicated aircraft.
 - Benefit the contestant with a specific and meaningful critique of his model, giving him direction for future improvements.

In scoring each box proceed as follows:

Highlight areas of mismatch on the diagram at right:

- Ask yourself "Is this item Outstanding (the best of the best)?"
Does the model match the documentation exactly (no deviations)?
If so, enter a 10 in the box for that group and proceed to the next box.
- If not, ask yourself, "What is missing, or different, that degrades it from being Outstanding?"
Briefly note each discrepancy in the Comments and mark the diagram at right at the location of the discrepancy.
- Deduct in 1/4 point increments corresponding to the severity of the noted defect (Refer to Judges Guide for additional details).
- Subtract the total discrepancy points for each box from 10 and enter the total points earned for that box.

Remember that an over-generous mark in even one box creates unfairness. It is unfair to everyone, even the recipient. A logical and honest mark is essential to every contestant and the well being of our sport.

ACCURACY OF OUTLINE

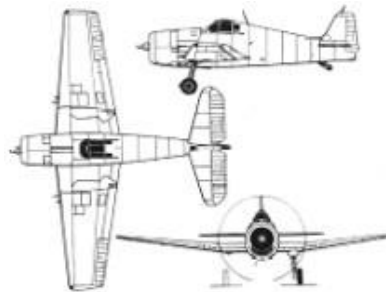

WINGS	OUTSTANDING	10	
	EXCELLENT	9	
	GOOD	7-8	
	FAIR	0-6	
FUSELAGE	OUTSTANDING	10	
	EXCELLENT	9	
	GOOD	7-8	
	FAIR	0-6	
TAIL GROUP	OUTSTANDING	10	
	EXCELLENT	9	
	GOOD	7-8	
	FAIR	0-6	
LANDING GEAR	OUTSTANDING	10	
	EXCELLENT	9	
	GOOD	7-8	
	FAIR	0-6	
TOTAL			

Max 40 points

COMMENTS: _____

STATIC JUDGING



Scale Masters Championships

Reg# _____

NAME: _____

AIRCRAFT: _____

NOTES TO JUDGES

This form is intended to accomplish the following aims:

- Promote scoring consistency among a wide assortment of replicated aircraft.
- Benefit the contestant with a specific and meaningful critique of his model, giving him direction for future improvements.

In scoring each box proceed as follows:

Highlight areas of mismatch on the diagram at right.

- 1) Ask yourself "Is this item Outstanding (the best of the best)?"

Does the model match the documentation exactly (no deviations)?

If so, enter a 10 in the box for that group and proceed to next box.

- 2) If not, ask yourself "What is missing or different that degrades it from being Outstanding?"

Briefly note each discrepancy in the Comments and mark the diagram at right at the location of the discrepancy.

- 3) Deduct in 1/4 point increments corresponding to the severity of the noted defect (Refer to Judges Guide for additional details).

- 4) Subtract the total discrepancy points for each box from 10 and enter the total points earned for that box.

Remember that an over-generous mark in even one box creates unfairness. It is unfair to everyone, even the recipient. A logical and honest mark is essential to every contestant and the well being of our sport.

COMMENTS: _____

FINISH, COLOR & MARKINGS

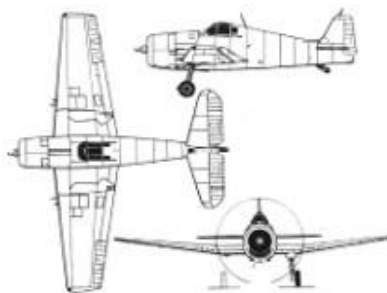

Guide for noting mismatches

Mark in 1/4 point increments

FINISH	OUTSTANDING	10	
	EXCELLENT	9	
	GOOD	7-8	
	FAIR	0-6	
COLORS (Max 5 points)	OUTSTANDING	5	
	EXCELLENT	4	
	GOOD	2-3	
	FAIR	0-1	
MARKINGS	OUTSTANDING	10	
	EXCELLENT	9	
	GOOD	7-8	
	FAIR	0-6	
TOTAL			

Max 25 points

STATIC JUDGING



Scale Masters Championships

Reg# _____

NAME: _____

AIRCRAFT: _____

NOTES TO JUDGES

- This form is intended to accomplish the following aims:
- Promote scoring consistency among a wide assortment of replicated aircraft.
 - Benefit the contestant with a specific and meaningful critique of his model, giving him direction for future improvements.

In scoring each box proceed as follows:

Highlight areas of mismatch on the diagram at right:

- Ask yourself "Is this item Outstanding (the best of the best)?"
Does the model match the documentation exactly (no deviations)?
If so, enter a 10 in the box for that group and proceed next box.
- If not, ask yourself "What is missing or different that degrades it from being Outstanding?"
Briefly note each discrepancy in the Comments and mark the diagram at right at the location of the discrepancy.
- Deduct in 1/4 point increments corresponding to the severity of the noted defect (Refer to Judges Guide for additional details).
- Subtract the total discrepancy points for each box from 10 and enter the total points earned for that box.

Remember that an over-generous mark in even one box creates unfairness. It is unfair to everyone, even the recipient. A logical and honest mark is essential to every contestant and the well being of our sport.

CRAFTSMANSHIP

Mark in 1/4 point increments

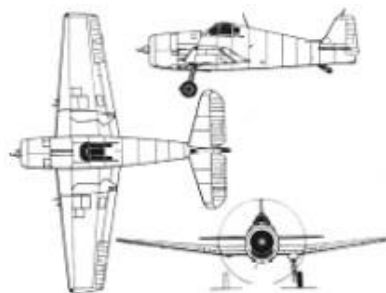

Guide for noting mismatches

WINGS	OUTSTANDING	10	
	EXCELLENT	9	
	GOOD	7-8	
	FAIR	0-6	
FUSELAGE	OUTSTANDING	10	
	EXCELLENT	9	
	GOOD	7-8	
	FAIR	0-6	
TAIL GROUP	OUTSTANDING	10	
	EXCELLENT	9	
	GOOD	7-8	
	FAIR	0-6	
LANDING GEAR (Max 5 points) (Craftsmanship Only)	OUTSTANDING	5	
	EXCELLENT	4	
	GOOD	2-3	
	FAIR	0-1	
TOTAL			

Max 35 points

COMMENTS: _____

**OPEN CLASS
STATIC JUDGING SHEET**

Reg# _____

NAME: _____



**Qualifier for the
U.S. Scale Masters Championships**

AIRCRAFT: _____

This form is intended to accomplish the following goals:

- a) Promote scoring consistency among a wide assortment of duplicated aircraft in the Open Class.
- b) Encourage the Open Class contestant to research and provide documentation for the model. The contestant is encouraged to modify the model to more closely match the documentation. This will help to advance his/her Scale modeling skills.

In scoring each box proceed as follows: NOTE If no documentation is provided, score all boxes zero (0).

- 1) Accuracy of Outline:
Outline will be based on 3 to 5 views that have been published or approved.
- 2) Color & Markings:
Documentation for color and markings requires published drawings, color chips and/or artist's renditions.
- 3) Craftsmanship:
Craftsmanship will be judged on the accuracy and quality of construction and the extent of detail added to the model.

Mark in full point increments

ACCURACY OF OUTLINE	OUTSTANDING 10	
	EXCELLENT 9	
	GOOD 7-8	
	FAIR 1-6	
	NO DOCUMENTATION PROVIDED: 0 POINTS	
COLOR & MARKINGS	OUTSTANDING 10	
	EXCELLENT 9	
	GOOD 7-8	
	FAIR 1-6	
	NO DOCUMENTATION PROVIDED: 0 POINTS	
CRAFTSMANSHIP	OUTSTANDING 10	
	EXCELLENT 9	
	GOOD 7-8	
	FAIR 1-6	
TOTAL		Max 30 points

Judge's Comments:



This graphic was painted by TSgt Tim Dougherty of the USAF. It honors the words made famous by Todd Beamer, passenger on board Flight 93 that crashed into a field in western Pennsylvania. Todd Beamer, a 32 year old business man, Sunday school teacher, husband, father and hero led other passengers in fighting the terrorists for control of the aircraft to prevent it from hitting the target designated by the terrorists. He was overheard on a cellular phone reciting the Lord's Prayer and saying "Let's roll!" as passengers then charged and overtook the terrorists. The Thunderbirds and other Air Force demonstration teams will apply this nose art on all aircraft while major commands and wings will be authorized to apply this to one aircraft of their choice. This will join the other famous paintings on the noses of our fighters and bombers over the years.

The U.S. Scale Masters Association is committed to promote and foster interest, education, and advancement in the sport of radio control Scale Aircraft Modeling by providing a competition environment that brings people together to learn while focusing on Scale realism, Competition, and Sportsmanship for the betterment of all.



US Scale Masters Association, Inc.
Bill Hart, National Chairman (714) 894-2747
9151 Larkspur Dr
Westminster, CA 92683-7324
billhartwestmin@yahoo.com

All proceeds from the sales of this Competition Guide are used to grow Scale Aircraft Modeling and to further Develop US Scale Masters Association.